

CCS

SECTION

CRUISE CONTROL SYSTEM

A
B
C
D
E
F
G
H
I
J
K
L
M
N
P

CONTENTS

ICC		
BASIC INSPECTION	4	
DIAGNOSIS AND REPAIR WORK FLOW	4	
Work Flow	4	
INSPECTION AND ADJUSTMENT	6	
ADDITIONAL SERVICE WHEN REPLACING CONTROL UNIT (ICC SENSOR INTEGRATED UNIT)	6	
ADDITIONAL SERVICE WHEN REPLACING CONTROL UNIT (ICC SENSOR INTEGRATED UNIT) : Description	6	
ADDITIONAL SERVICE WHEN REPLACING CONTROL UNIT (ICC SENSOR INTEGRATED UNIT) : Special Repair Requirement	6	
LASER BEAM AIMING ADJUSTMENT	6	
LASER BEAM AIMING ADJUSTMENT : Description	6	
LASER BEAM AIMING ADJUSTMENT : Special Repair Requirement (Preparation)	7	
LASER BEAM AIMING ADJUSTMENT : Special Repair Requirement (Setting The ICC Target Board)	7	
LASER BEAM AIMING ADJUSTMENT : Special Repair Requirement (Laser Beam Aiming Adjustment)	10	
ACTION TEST	11	
ACTION TEST : Description	11	
ACTION TEST : Special Repair Requirement (Vehicle-To-Vehicle Distance Control Mode)	11	
ACTION TEST : Special Repair Requirement [Conventional (Fixed Speed) Cruise Control Mode]	14	
SYSTEM DESCRIPTION	17	
ICC	17	
	System Diagram	17
	System Description	17
	Component Parts Location	20
	Component Description	21
	VEHICLE-TO-VEHICLE DISTANCE CONTROL MODE FUNCTION	22
	System Diagram	22
	System Description	22
	Component Parts Location	29
	Component Description	30
	CONVENTIONAL (FIXED SPEED) CRUISE CONTROL MODE FUNCTION	31
	System Diagram	31
	System Description	31
	Component Parts Location	35
	Component Description	36
	DIAGNOSIS SYSTEM (ICC SENSOR INTEGRATED UNIT)	37
	Diagnosis Description	37
	CONSULT-III Function (ICC)	38
	DTC/CIRCUIT DIAGNOSIS	43
	C1A00 CONTROL UNIT	43
	Description	43
	DTC Logic	43
	Diagnosis Procedure	43
	Special Repair Requirement	43
	C1A01 POWER SUPPLY CIRCUIT 1, C1A02 POWER SUPPLY CIRCUIT 2	45
	Description	45
	DTC Logic	45
	Diagnosis Procedure	45
	Special Repair Requirement	45
	C1A03 VEHICLE SPEED SENSOR	47
	Description	47
	DTC Logic	47



Diagnosis Procedure (A/T Models)	47	Diagnosis Procedure	77
Diagnosis Procedure (M/T Models)	48	Special Repair Requirement	77
Special Repair Requirement	48		
C1A04 ABS/TCS/VDC SYSTEM	50	C1A21 UNIT HIGH TEMP	79
Description	50	Description	79
DTC Logic	50	DTC Logic	79
Diagnosis Procedure	50	Diagnosis Procedure	79
Special Repair Requirement	50	Special Repair Requirement	79
C1A05 BRAKE SW/STOP LAMP SW	52	C1A24 NP RANGE	81
Description	52	Description	81
DTC Logic	52	DTC Logic	81
Diagnosis Procedure (A/T Models)	52	Diagnosis Procedure	81
Diagnosis Procedure (M/T Models)	55	Special Repair Requirement	82
Component Inspection (ICC Brake Switch)	58		
Component Inspection (ICC Clutch Switch)	58	C1A26 ECD MODE MALFUNCTION	83
Component Inspection (Stop Lamp Switch)	58	Description	83
Special Repair Requirement	58	DTC Logic	83
		Diagnosis Procedure	83
C1A06 OPERATION SW	60	Special Repair Requirement	83
Description	60		
DTC Logic	60	C1A27 ECD POWER SUPPLY CIRCUIT	85
Diagnosis Procedure	60	Description	85
Component Inspection	61	DTC Logic	85
Special Repair Requirement	62	Diagnosis Procedure	85
		Special Repair Requirement	86
C1A12 LASER BEAM OFF CENTER	63		
Description	63	C1A33 CAN TRANSMISSION ERROR	87
DTC Logic	63	Description	87
Diagnosis Procedure	63	DTC Logic	87
Special Repair Requirement	63	Diagnosis Procedure	87
		Special Repair Requirement	87
C1A13 STOP LAMP RELAY	64		
Description	64	C1A34 COMMAND ERROR	89
DTC Logic	64	Description	89
Diagnosis Procedure	64	DTC Logic	89
Component Inspection	69	Diagnosis Procedure	89
Special Repair Requirement	69	Special Repair Requirement	89
C1A14 ECM	70		
Description	70	U0121 VDC CAN 2	91
DTC Logic	70	Description	91
Diagnosis Procedure	70	DTC Logic	91
Special Repair Requirement	70	Diagnosis Procedure	91
		Special Repair Requirement	91
C1A15 GEAR POSITION	72		
Description	72	U0401 ECM CAN 1	93
DTC Logic	72	Description	93
Diagnosis Procedure	72	DTC Logic	93
Special Repair Requirement	73	Diagnosis Procedure	93
		Special Repair Requirement	93
C1A16 RADAR STAIN	75		
Description	75	U0402 TCM CAN 1	95
DTC Logic	75	Description	95
Diagnosis Procedure	75	DTC Logic	95
Special Repair Requirement	75	Diagnosis Procedure	95
		Special Repair Requirement	95
C1A18 LASER AIMING INCOMP	77		
Description	77	U0415 VDC CAN 1	97
DTC Logic	77	Description	97
		DTC Logic	97
		Diagnosis Procedure	97

Special Repair Requirement	97	Diagnosis Procedure	122
U1000 CAN COMM CIRCUIT	99	ICC SYSTEM DOES NOT CANCEL WHEN A/ T SELECTOR LEVER SETS ON "N"	123
Description	99	Description	123
DTC Logic	99	Diagnosis Procedure	123
Diagnosis Procedure	99	CHIME DOES NOT SOUND	124
Special Repair Requirement	99	Description	124
U1010 CONTROL UNIT (CAN)	101	Diagnosis Procedure	124
Description	101	DRIVING FORCE IS HUNTING	126
DTC Logic	101	Description	126
Diagnosis Procedure	101	Diagnosis Procedure	126
Special Repair Requirement	101	FREQUENTLY CANNOT DETECT THE VEHI- CLE AHEAD / DETECTION ZONE IS SHORT. 127	
POWER SUPPLY AND GROUND CIRCUIT ... 102		Description	127
Diagnosis Procedure	102	Diagnosis Procedure	127
PARK/NEUTRAL POSITION SWITCH CIR- CUIT	103	THE SYSTEM DOES NOT DETECT THE VE- HICLE AHEAD AT ALL	128
Description	103	Description	128
Component Function Check	103	Diagnosis Procedure	128
Diagnosis Procedure	103	NORMAL OPERATING CONDITION	129
Component Inspection	104	Description	129
ECU DIAGNOSIS INFORMATION	105	PRECAUTION	132
ICC SENSOR INTEGRATED UNIT	105	PRECAUTIONS	132
Reference Value	105	Precaution for Supplemental Restraint System (SRS) "AIR BAG" and "SEAT BELT PRE-TEN- SIONER"	132
Wiring Diagram - INTELLIGENT CRUISE CON- TROL -	108	Precaution for Battery Service	132
Fail-Safe	115	Service Procedure Precautions for Models with a Pop-up Roll Bar	132
DTC Inspection Priority Chart	115	ICC System Service	132
DTC Index	116	PREPARATION	134
SYMPTOM DIAGNOSIS	118	PREPARATION	134
INTELLIGENT CRUISE CONTROL SYSTEM SYMPTOMS	118	Special Service Tools	134
Symptom Table	118	REMOVAL AND INSTALLATION	135
MAIN SWITCH DOES NOT TURN ON, MAIN SWITCH DOES NOT TURN OFF	119	ICC SENSOR INTEGRATED UNIT	135
Description	119	Exploded View	135
Diagnosis Procedure	119	Removal and Installation	135
ICC SYSTEM CANNOT BE SET (MAIN SWITCH TURNS ON/OFF)	120	ICC STEERING SWITCH	137
Description	120	Exploded View	137
Diagnosis Procedure	120		
ICC STEERING SWITCH (OTHER THAN MAIN SWITCH) DOES NOT FUNCTION	122		
Description	122		

A
B
C
D
E
F
G
H
I
J
K
L
M
N
P

CCS

DIAGNOSIS AND REPAIR WORK FLOW

< BASIC INSPECTION >

[ICC]

BASIC INSPECTION

DIAGNOSIS AND REPAIR WORK FLOW

Work Flow

INFOID:000000005622506

OVERALL SEQUENCE

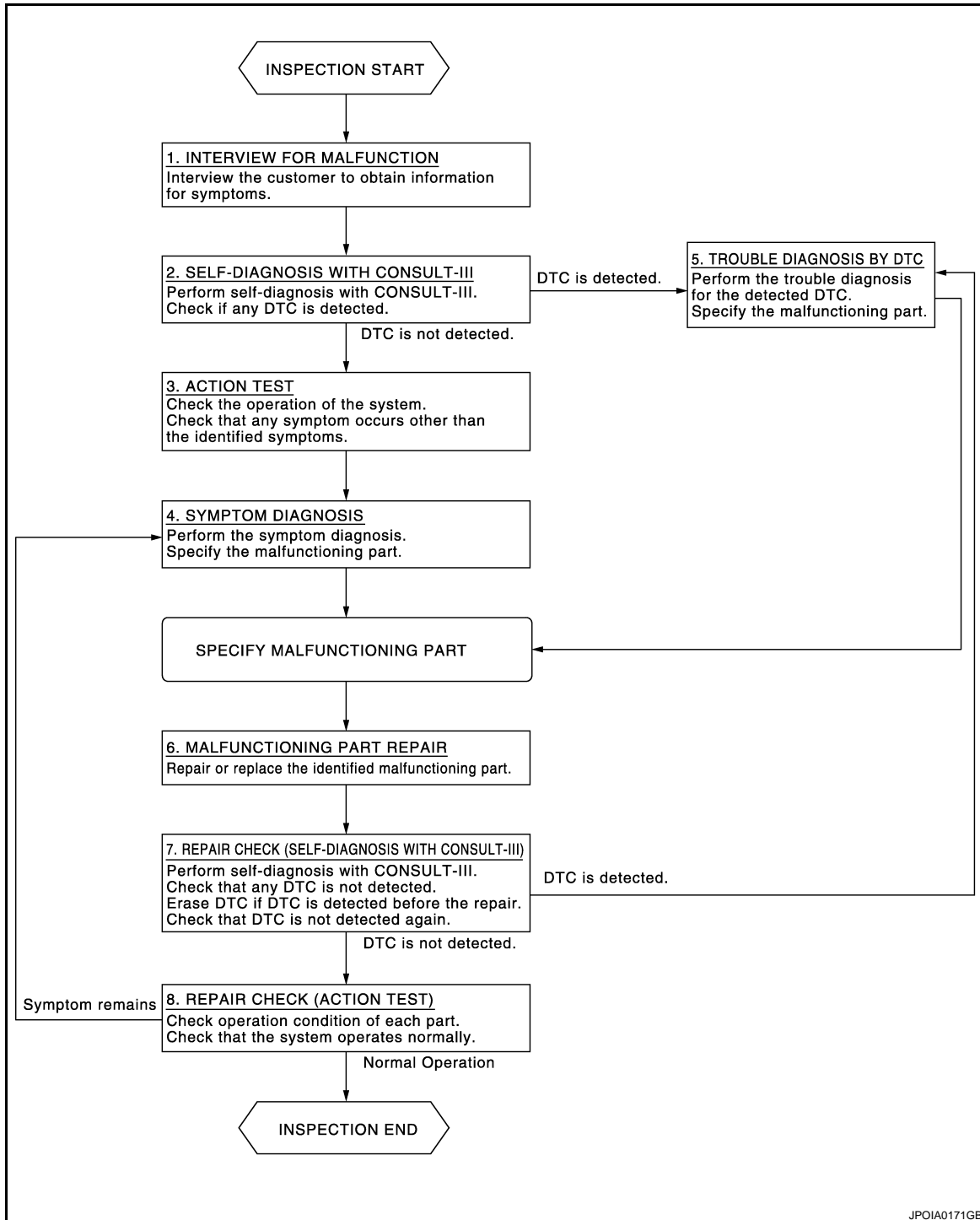

DETAILED FLOW

1. INTERVIEW FOR MALFUNCTION

It is also important to clarify the customer concerns before starting the inspection. Interview the customer about the concerns carefully and understand the symptoms fully.

DIAGNOSIS AND REPAIR WORK FLOW

[ICC]

< BASIC INSPECTION >

NOTE:

The customers are not professionals. Never assume that “maybe the customer means...” or “maybe the customer mentioned this symptom”.

>> GO TO 2.

2.SELF-DIAGNOSIS WITH CONSULT-III

1. Perform “All DTC Reading” with CONSULT-III.
2. Check if any DTC is detected in self-diagnosis results of “ICC”.

Is any DTC detected?

YES >> GO TO 5.

NO >> GO TO 3.

3.ACTION TEST

Perform the ICC system action test to check the operation status. Refer to [CCS-11, "ACTION TEST : Description"](#).

Check if any other malfunctions occur.

>> GO TO 4.

4.SYMPTOM DIAGNOSIS

Perform the applicable diagnosis according to the diagnosis chart by symptom. Refer to [CCS-118, "Symptom Table"](#).

>> GO TO 6.

5.TROUBLE DIAGNOSIS BY DTC

1. Check the DTC in the self-diagnosis results.
2. Perform trouble diagnosis for the detected DTC. Refer to [CCS-116, "DTC Index"](#).

NOTE:

If “DTC: U1000” is detected, first diagnose the CAN communication system.

>> GO TO 6.

6.MALFUNCTIONING PART REPAIR

Repair or replace the identified malfunctioning parts.

>> GO TO 7.

7.REPAIR CHECK (SELF-DIAGNOSIS WITH CONSULT-III)

1. Erases self-diagnosis results.
2. Perform “All DTC Reading” again after repairing or replacing the malfunctioning parts.
3. Check if any DTC is detected in self-diagnosis results of “ICC”.

Is any DTC detected?

YES >> GO TO 5.

NO >> GO TO 8.

8.REPAIR CHECK (ACTION TEST)

Perform the ICC system action test. Check if the malfunction symptom is solved or no other symptoms occur.

Is there any malfunction symptom?

YES >> GO TO 4.

NO >> INSPECTION END

A
B
C
D
E
F
G
H
I
J
K
L
M
N
P

CCS

INSPECTION AND ADJUSTMENT

< BASIC INSPECTION >

[ICC]

INSPECTION AND ADJUSTMENT

ADDITIONAL SERVICE WHEN REPLACING CONTROL UNIT (ICC SENSOR INTEGRATED UNIT)

ADDITIONAL SERVICE WHEN REPLACING CONTROL UNIT (ICC SENSOR INTEGRATED UNIT) : Description

INFOID:000000005622507

- Always perform the laser beam aiming adjustment after removing and installing or replacing the ICC sensor integrated unit.

CAUTION:

The system does not operate normally unless the laser beam aiming adjustment is performed. Always perform it.

- Perform the ICC system action test to check that the ICC system operates normally.

ADDITIONAL SERVICE WHEN REPLACING CONTROL UNIT (ICC SENSOR INTEGRATED UNIT) : Special Repair Requirement

INFOID:000000005622508

1. LASER BEAM AIMING ADJUSTMENT

Adjust the laser beam aiming. Refer to [CCS-6. "LASER BEAM AIMING ADJUSTMENT : Description"](#).

>> GO TO 2.

2. ICC SYSTEM ACTION TEST

1. Perform the ICC system action test. Refer to [CCS-11. "ACTION TEST : Description"](#).
2. Check that the ICC system operates normally.

>> INSPECTION END

LASER BEAM AIMING ADJUSTMENT

LASER BEAM AIMING ADJUSTMENT : Description

INFOID:000000005622509

OUTLINE OF LASER BEAM AIMING ADJUSTMENT

Always adjust the laser beam aiming after removing and installing or replacing the ICC sensor integrated unit.

CAUTION:

The system does not operate normally unless the laser beam aiming adjustment is performed. Always perform it.

1. Set the ICC target board [SST: KV99110100 (J-45718)] to the correct position in front of the vehicle.

NOTE:

The location of the ICC sensor integrated unit (1) differs according to the front bumper fascia type. So the ICC target board setting position varies accordingly.

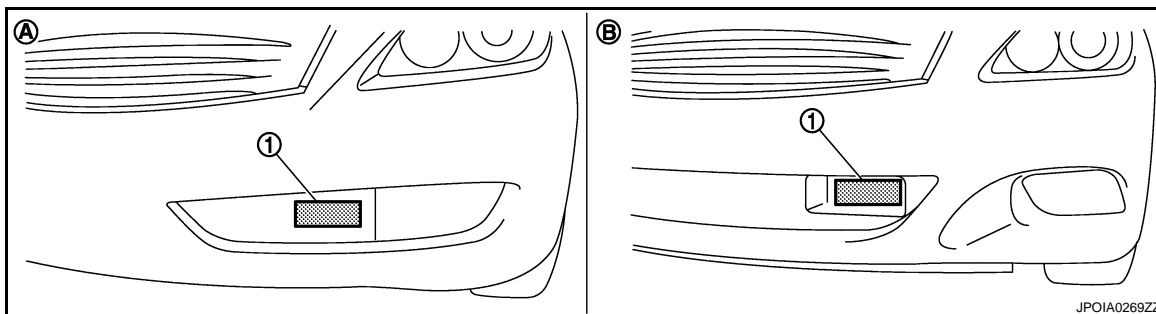

A : Normal front bumper fascia type B : Sport front bumper fascia type

2. Set the laser beam aiming mode ("LASER BEAM ADJUST" on "Work support") with CONSULT-III, and then perform the adjustment according to the display. (Manually turn the up-down direction adjusting

INSPECTION AND ADJUSTMENT

< BASIC INSPECTION >

[ICC]

screw for vertical adjustment. ICC sensor integrated unit adjusts the automatic aiming for the horizontal direction.)

CAUTIONARY POINT FOR LASER BEAM AIMING ADJUSTMENT

CAUTION:

- For laser beam aiming adjustment, choose a level location where a view can be obtained without any obstruction as far as 12 m (39 ft) or more in the forward direction.
- Adjust laser beam aiming for 5 seconds or more after starting engine.
- Adjust the laser beam aiming with CONSULT-III. (The laser beam aiming cannot be adjusted without CONSULT-III.)
- Never enter the vehicle during laser beam aiming adjustment.
- Never look directly into the laser beam source (ICC sensor integrated unit body window) during laser beam aiming adjustment.
- Laser beam aiming adjustment is performed at idle. At this time, turn the headlamps OFF.

LASER BEAM AIMING ADJUSTMENT : Special Repair Requirement (Preparation)

INFOID:0000000005622510

1. ADVANCE PREPARATION FOR LASER BEAM AIMING ADJUSTMENT

1. Adjust all tire pressure to the specified value.
2. Empty the vehicle. (Remove any luggage from the passenger compartment, luggage room, etc.)
3. Shift the selector lever to the "P" position (A/T models) or the shift knob to the neutral position (M/T models), and release the parking brake.

CAUTION:

Apply wheel chocks or other tire blocks to the wheels to prevent the vehicle from moving.

4. Fully fill the fuel tank, and then check that the coolant and oils are filled up to correct level.
5. Clean off the ICC sensor integrated unit body window with a soft cloth.

>> Go to [CCS-7. "LASER BEAM AIMING ADJUSTMENT : Special Repair Requirement \(Setting The ICC Target Board\)".](#)

LASER BEAM AIMING ADJUSTMENT : Special Repair Requirement (Setting The ICC Target Board)

INFOID:0000000005622511

DESCRIPTION

Accurate adjustment of the laser beam requires that the ICC target board be accurately positioned.

CAUTION:

If the laser beam is adjusted with the ICC target board in the incorrect position, the ICC system does not function normally.

1. ICC TARGET BOARD HEIGHT ADJUSTMENT

1. Attach the triangle scale (2) at 42 mm (1.65 in) (H) below the center (A) of the ICC target board (1).

3 : Adjust nut

b : 90°

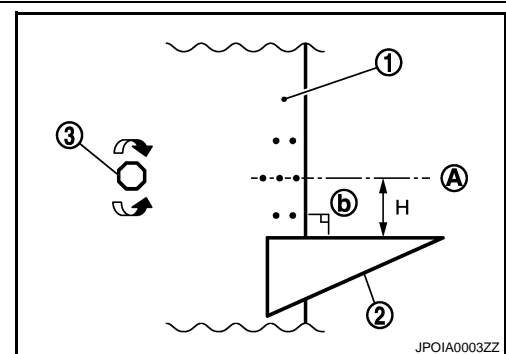

INSPECTION AND ADJUSTMENT

[ICC]

< BASIC INSPECTION >

2. Adjust the ICC target board height to the position aligning the triangle scale (1) upper side tip with the center of laser beam axis (A).

2 : ICC sensor integrated unit

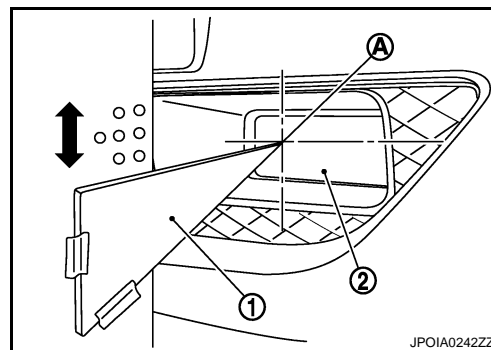

NOTE:

- The center of laser beam axis (A) is located at 38 mm (1.5 in) (W) from the left end of ICC sensor integrated unit and 22 mm (H) (0.87 in) from above when viewed from the front of the vehicle.

B : Up-down direction adjusting screw

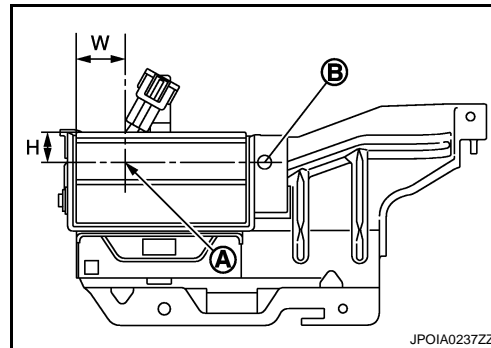

- To identify the laser beam axis center (A) easily, prepare a piece of paper (B) cut to the size of 38 mm (1.5 in) (W) × 22 mm (0.87 in) (H) and attach it on the upper left point of the ICC sensor integrated unit (1).

>> GO TO 2.

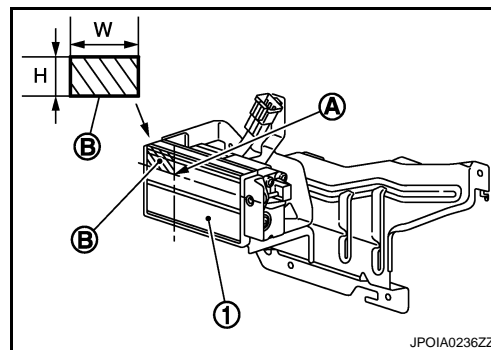

2.ADJUSTING SIDE POSITION OF ICC TARGET BOARD

1. On the back of the ICC target board, attach the ruler (1) [450 mm (17.72 in) or more] squarely from the ICC target board center (A) in the left direction.

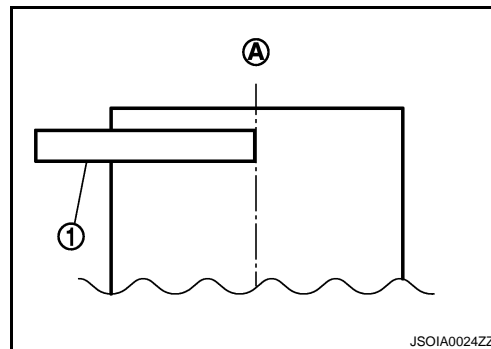

INSPECTION AND ADJUSTMENT

[ICC]

< BASIC INSPECTION >

- Suspend a weight from a string (1) attached to its end at the point (B) rightward from the ICC target board center (A).

W [mm (in)]

Normal front bumper fascia type : 404 (15.91)

Sport front bumper fascia type : 247 (9.72)

>> GO TO 3.

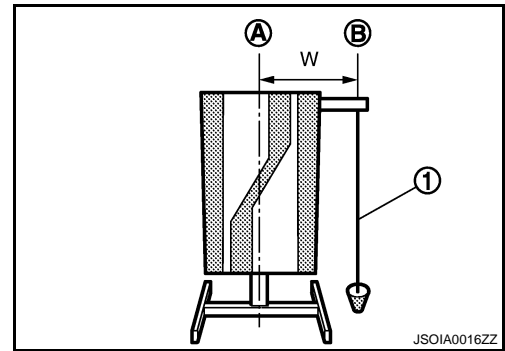

3.SETTING ICC TARGET BOARD

- Suspend a thread with weight on tip from the center of the front and rear bumpers. Then, mark the center points on the ground as each weight point.
- Link the front and rear bumpers center points marked on the ground and extend a straight line ahead. Then mark a point 3.9 m (12.8 ft) position ahead of the front bumper. Then, adjust the position of the ICC target board so that the weight comes on the top of the marked point [3.9 m (12.8 ft) position ahead of the front bumper] and face to the vehicle.
- Remove the thread suspended to the right side of ICC target board and suspend a thread with weight on tip on the center of the ICC target board. Then mark the point of weight on the ground.
- Pivot the edge of the ICC target board 25° (a) to either side.

1 : ICC target board

2 : String with a weight

C : ICC target board center marking point

NOTE:

Approx. 90 mm (3.54 in) (b) shift rates the 25° (a) movement.

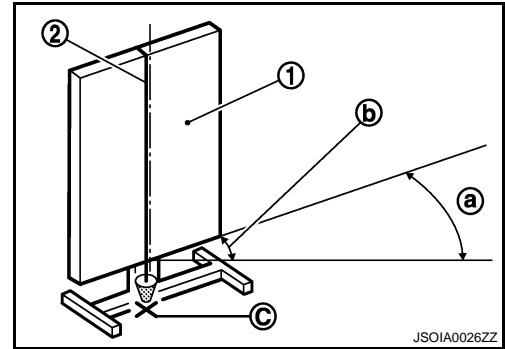

>> GO TO 4.

4.CHECK THE ICC TARGET BOARD INSTALLATION POSITION

Check that the ICC target board (1) is located as shown in the figure.

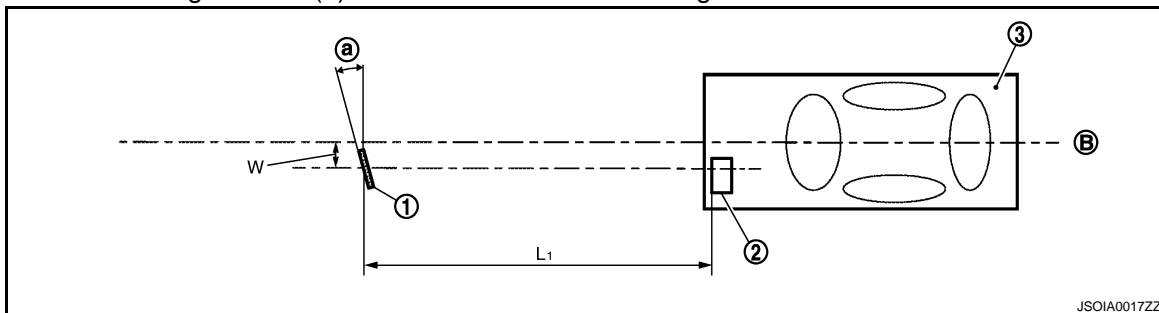

1. ICC target board

2. ICC sensor integrated unit

3. Vehicle

B. Vehicle center

L1. 4.0 m (13.0 ft)

W. 404 mm (15.91 in) (Normal front bumper fascia type)

247 mm (9.72 in) (Sport front bumper fascia type)

a. 25°

NOTE:

The distance between laser beam axis and ICC target board is 4.0 m (13.0 ft).

>> GO TO 5.

A
B
C
D
E
F
G
H
I
J
K
L
M
N

P

INSPECTION AND ADJUSTMENT

< BASIC INSPECTION >

[ICC]

5. CHECK THE ICC TARGET BOARD INSTALLATION AREA

Do not place anything other than ICC target board in the space shown in the figure (view from top).

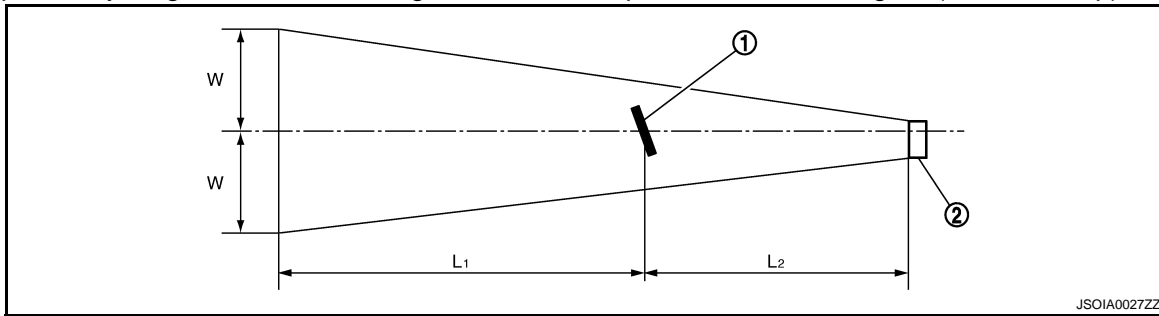

1. ICC target board

L1. 6.5 m (21.3 ft)

2. ICC sensor integrated unit

L2. 4.0 m (13.0 ft)

W. 3.5 m (11.5 ft)

NOTE:

In case the space shown in the figure is not available, cover the side of the ICC target board with a 1400 mm (4.6 ft)-size frosted black board or black cloth.

>> Go to [CCS-10, "LASER BEAM AIMING ADJUSTMENT : Special Repair Requirement \(Laser Beam Aiming Adjustment\)"](#).

LASER BEAM AIMING ADJUSTMENT : Special Repair Requirement (Laser Beam Aiming Adjustment)

INFOID:000000005622512

DESCRIPTION

- Adjust the laser beam aiming in a vertical direction with CONSULT-III as per the following.
- The laser beam aiming adjustment in a horizontal direction is performed automatically with CONSULT-III.

CAUTION:

- **Never look directly into the laser beam source (ICC sensor integrated unit body window) during laser beam aiming adjustment.**
- **Perform all necessary work for laser beam aiming adjustment until the adjustment completes as shown in the procedure. If the procedure does not complete, the ICC system is inoperable.**

1. SET CONSULT-III TO THE LASER BEAM AIMING ADJUSTMENT MODE

1. Start the engine.
2. Connect CONSULT-III and select "Work support" of "ICC".
3. Select "LASER BEAM ADJUST" after the "Work support" screen is displayed.
4. Select "START" after the "LASER BEAM ADJUST" screen is displayed.

NOTE:

If the adjustment screen does not appear within approximately 10 seconds after "LASER BEAM ADJUST" is selected, the following causes are possible.

- The ICC target board is not installed in the correct position.
- Adequate space is not secured around the ICC target board.
- The laser beam aiming adjustment exceeds its proper installation range.
 - Deformation of vehicle body.
 - Deformation of unit.
 - Deformation of bracket.
- The area is not suitable for the adjustment work.
- ICC sensor integrated unit body window is not clean.
- The ICC system warning lamp illuminates.

>> GO TO 2.

2. LASER BEAM AIMING ADJUSTMENT

After "ADJUST THE VERTICAL OF LASER BEAM AIMING" is displayed on CONSULT-III screen, adjust by turning the up-down direction adjusting screw until "U/D CORRECT" becomes ± 4 or less.

NOTE:

INSPECTION AND ADJUSTMENT

[ICC]

< BASIC INSPECTION >

- Turn the up-down direction adjusting screw slowly. The value change on display is slower than actual movement of the ICC sensor integrated unit. Wait for 2 seconds every time the up-down direction adjusting screw is turned half a rotation.
- Turning the up-down direction adjusting screw (A) clockwise directs the laser beam downward (B). The laser beam directs upward (C) when turning up-down direction adjusting screw counterclockwise.

CAUTION:

Be careful not to cover the ICC sensor integrated unit body window with a hand or the other part of body of worker during adjustment.

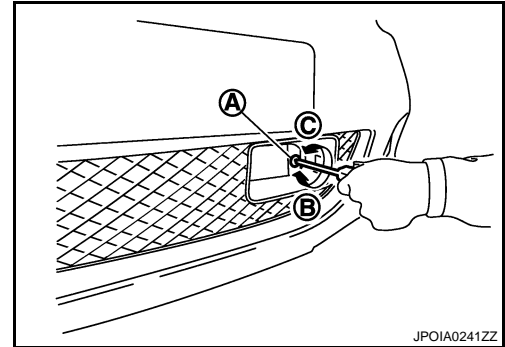

>> GO TO 3.

3. LASER BEAM AIMING CONFIRMATION

1. When the "U/D CORRECT" value becomes ± 4 or less, check that no value greater than ± 4 appears when the vehicle is left with no load on the ICC sensor integrated unit (hand removed) for at least 2 seconds.
2. When "COMPLETED THE VERTICAL AIMING OF LASER BEAM" display appears, touch "END".

CAUTION:

Always check that the value of "U/D CORRECT" remains ± 4 or less when the ICC sensor integrated unit is left alone for at least 2 seconds.

3. Check that "ADJUSTING AUTOMATIC HORIZONTAL LASER BEAM AIMING" is displayed and wait for a short period of time. (The maximum: Approx 10 seconds).
4. Check that "Normally Completed" is displayed, and select "End" to end "LASER BEAM ADJUST".

CAUTION:

Once "LASER BEAM ADJUST" is started with CONSULT-III, always continue the work until the horizontal laser beam aiming adjustment is completed successfully. If the job is stopped midway, the laser beam aiming is not adjusted and the ICC system cannot operate.

>> LASER BEAM AIMING ADJUSTMENT END

ACTION TEST

ACTION TEST : Description

INFOID:000000005622513

Always perform the ICC system action test to check that the ICC system operates normally after replacing the ICC sensor integrated unit or repairing any ICC system malfunction.

CAUTION:

Always drive safely when performing the action test.

ACTION TEST : Special Repair Requirement (Vehicle-To-Vehicle Distance Control Mode)

INFOID:000000005622514

NOTE:

- When there is no vehicle ahead, drive at the set speed steadily.
 - The set speed can be selected by the driver between 40 to 144 km/h (25 to 90 MPH).
- When there is a vehicle ahead, control to maintain distance from the vehicle ahead, watching its speed.
 - Maintains a selected distance from the vehicle in front of own vehicle within the speed range of 40 to 144 km/h (25 to 90 MPH) up to the set speed.

CAUTION:

Never set the cruise speed exceeding the posted speed limit.

1. CHECK FOR MAIN SWITCH

1. Start the engine.

INSPECTION AND ADJUSTMENT

< BASIC INSPECTION >

[ICC]

- Press the MAIN switch (1) (less than 1.5 seconds).

Information display status		
MAIN switch indicator (2)	:	ON
Set distance indicator (3)	:	Long mode
Own vehicle indicator (4)	:	ON
Set vehicle speed indicator (5)	:	"_ _ _" "km/h" ("MPH")

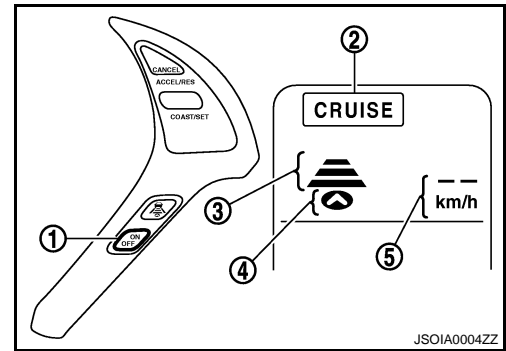

- Check the ICC system display on the information display to check that the vehicle-to-vehicle distance control mode is ready for activation.
- Press the MAIN switch, and check that the ICC system display on the information display turns OFF when the ICC system is deactivated.
- Check that the ICC system display on the information display turns OFF after starting the engine again.

>> GO TO 2.

2. CHECK FOR DISTANCE SWITCH

- Start the engine.
- Press the MAIN switch (less than 1.5 seconds).
- Press the DISTANCE switch.
- Check that the set distance indicator changes display in order of: (Long)→(Middle)→(Short).

Distance	Display	Approximate distance at 100 km/h (60 MPH) [m (ft)]
Long	100 km/h	60 (200)
Middle	100 km/h	45 (150)
Short	100 km/h	30 (100)

NOTE:

When the MAIN switch is turned ON, initial setting set to (Long).

>> GO TO 3.

3. CHECK FOR RESUME/ACCELERATE, SET/COAST, AND CANCEL SWITCHES

- Check that RESUME/ACCELERATE, SET/COAST, and CANCEL switches are operated smoothly.
- Check that switches come up as hand is released from the switches.

>> GO TO 4.

4. SET CHECKING

- Start the engine.
- Press the MAIN switch (less than 1.5 seconds) and turn the vehicle-to-vehicle distance control mode ON.
- Drive the vehicle at 40 km/h (25 MPH) or more.

INSPECTION AND ADJUSTMENT

[ICC]

< BASIC INSPECTION >

4. Push down the SET/COAST switch.
5. Check that the desired speed is set and vehicle-to-vehicle distance control mode control starts when releasing SET/COAST switch.

NOTE:

The set vehicle speed is indicated on the set vehicle speed indicator in the ICC system display on the information display.

>> GO TO 5.

5.CHECK FOR INCREASE OF CRUISING SPEED

1. Set the vehicle-to-vehicle distance control mode at desired speed.
2. Check that the set speed increases by 1 km/h (1 MPH) as RESUME/ACCELERATE switch is pushed up.

NOTE:

The maximum set speed of the vehicle-to-vehicle distance control mode is 144 km/h (90 MPH).

CAUTION:

Never set the cruise speed exceeding the posted speed limit.

>> GO TO 6.

6.CHECK FOR DECREASE OF CRUISING SPEED

1. Set the vehicle-to-vehicle distance control mode at desired speed.
2. Check that the set speed decreases by 1 km/h (1 MPH) as SET/COAST switch is pushed down.

NOTE:

- The minimum set speed is approximately 40 km/h (25 MPH).
- Cancel the control automatically when the vehicle speed is less than approximately 32 km/h (20 MPH) and when the system does not detect any vehicle ahead.

>> GO TO 7.

7.CHECK FOR CANCELLATION OF VEHICLE-TO-VEHICLE DISTANCE CONTROL MODE

Check that the vehicle-to-vehicle distance control mode is canceled when performing the following operations.

- When the brake pedal is depressed after vehicle-to-vehicle distance control mode is set and the vehicle is driven.
- When the clutch pedal is depressed after vehicle-to-vehicle distance control mode is set and the vehicle is driven. (M/T models)
- When the selector lever is in the "N" position after vehicle-to-vehicle distance control mode is set and the vehicle is driven. (A/T models)
- When the MAIN switch is turned OFF after vehicle-to-vehicle distance control mode is set and the vehicle is driven.
- When the CANCEL switch is pressed after vehicle-to-vehicle distance control mode is set and the vehicle is driven.

>> GO TO 8.

8.CHECK FOR RESTORING SPEED THAT IS SET BY VEHICLE-TO-VEHICLE DISTANCE CONTROL MODE BEFORE CANCELLATION

Check that the vehicle restores the previous speed kept before the system deactivation when performing the following operations.

- Drive the vehicle when the vehicle-to-vehicle distance control mode is set and depress the brake pedal to cancel the control. Check that the vehicle restores the previous vehicle speed kept before the system deactivation when pushing up the RESUME/ACCELERATE switch.
- Drive the vehicle when the vehicle-to-vehicle distance control mode is set and depress the clutch pedal (with the shift knob at any of the 1st to 6th gear positions) to cancel the control. Check that the vehicle restores the previous vehicle speed kept before the system deactivation when pushing up the RESUME/ACCELERATE switch. (M/T models)
- Drive the vehicle when the vehicle-to-vehicle distance control mode is set and shift the selector lever to the "N" position to cancel the control. Check that the vehicle restores the previous vehicle speed kept before the system deactivation when shifting the selector lever to the "D" position and pushing up the RESUME/ACCELERATE switch. (A/T models)

A
B
C
D
E
F
G
H
I
J
K
L
M
N

CCS

P

INSPECTION AND ADJUSTMENT

< BASIC INSPECTION >

[ICC]

- Drive the vehicle when the vehicle-to-vehicle distance control mode is set and press the CANCEL switch to cancel the control. Check that the vehicle restores the previous vehicle speed kept before the system deactivation when pushing up the RESUME/ACCELERATE switch.

>> INSPECTION END

ACTION TEST : Special Repair Requirement [Conventional (Fixed Speed) Cruise Control Mode]

INFOID:000000005622515

NOTE:

- For cruising at a preset speed.
- The set speed can be selected by the driver between 40 to 144 km/h (25 to 90 MPH).

CAUTION:

Never set the cruise speed exceeding the posted speed limit.

1. CHECK FOR MAIN SWITCH

1. Start the engine.
2. Press the MAIN switch (1) (1.5 seconds or more).

Information display status
MAIN switch indicator (2) : ON

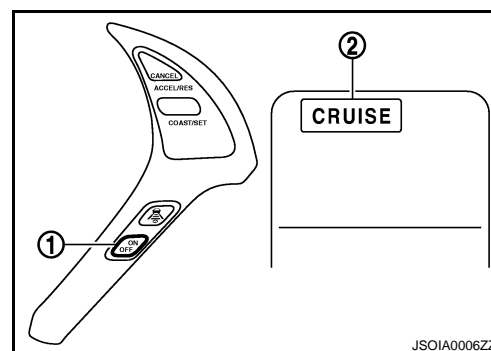

3. Check that the ICC system display on the information display turns on and the display is ready for activation.
4. Press the MAIN switch, and check that the ICC system display on the information display turns OFF when the ICC system is deactivated.
5. Check that the ICC system display on the information display turns OFF after starting the engine again.

>> GO TO 2.

2. CHECK FOR RESUME/ACCELERATE, SET/COAST, AND CANCEL SWITCHES

1. Check that RESUME/ACCELERATE, SET/COAST, and CANCEL switches are operated smoothly.
2. Check that switches come up as hand is released from the switches.

>> GO TO 3.

3. SET CHECKING

1. Start the engine.
2. Press the MAIN switch (1.5 seconds or more) and turn the conventional (fixed speed) cruise control mode to ON.
3. Drive the vehicle at 40 km/h (25 MPH) or more.
4. Push down the SET/COAST switch.
5. Check that the desired speed is set and conventional (fixed speed) cruise control mode control starts when releasing SET/COAST switch.

NOTE:

- The set vehicle speed is not displayed in the ICC system display on the information display.
- Display the set status in the ICC system display on the information display.

>> GO TO 4.

4. CHECK FOR INCREASE OF CRUISING SPEED

1. Set the vehicle speed to any desired speed, and drive the vehicle.

INSPECTION AND ADJUSTMENT

[ICC]

< BASIC INSPECTION >

2. Check that the set speed increases by 1.6 km/h (1 MPH) as RESUME/ACCELERATE switch is pushed up.

NOTE:

- The maximum set speed is 144 km/h (90 MPH).
- The set vehicle speed increases while pushing up the RESUME/ACCELERATE switch.

CAUTION:

Never set the cruise speed exceeding the posted speed limit.

>> GO TO 5.

5. CHECK FOR DECREASE OF CRUISING SPEED

1. Set the vehicle speed to any desired speed, and drive the vehicle.
2. Check that the set speed decreases by 1.6 km/h (1 MPH) as SET/COAST switch is pushed down.

NOTE:

- The minimum set speed is 40 km/h (25 MPH).
- The set vehicle speed decreases while pressing down the SET/COAST switch.
- Cancel the control automatically when the vehicle speed lowers to less than approximately 32 km/h (20 MPH).

>> GO TO 6.

6. CHECK FOR CANCELLATION OF CONVENTIONAL (FIXED SPEED) CRUISE CONTROL MODE

Check that the conventional (fixed speed) cruise control mode is canceled when performing the following operations.

- When the brake pedal is depressed after the conventional (fixed speed) cruise control mode is set and the vehicle is driven.
- When the clutch pedal is depressed after the conventional (fixed speed) cruise control mode is set and the vehicle is driven. (M/T models)
- When the selector lever is in the "N" position after the conventional (fixed speed) cruise control mode is set and the vehicle is driven. (A/T models)
- When the MAIN switch is turned OFF after the conventional (fixed speed) cruise control mode is set and the vehicle is driven.
- When the CANCEL switch is pressed after the conventional (fixed speed) cruise control mode is set and the vehicle is driven.

>> GO TO 7.

7. CHECK FOR RESTORING SPEED THAT IS SET BY CONVENTIONAL (FIXED SPEED) CRUISE CONTROL MODE BEFORE CANCELLATION

Check that the vehicle restores the previous speed kept before the system deactivation when performing the following operations.

- Drive the vehicle when the conventional (fixed speed) cruise control mode is set and depress the brake pedal to cancel the control. Check that the vehicle restores the previous vehicle speed kept before the system deactivation when pushing up the RESUME/ACCELERATE switch at the vehicle speed approximately 40 km/h (25 MPH) or more.
- Drive the vehicle when the conventional (fixed speed) cruise control mode is set and depress the clutch pedal (with the shift knob at any of the 1st to 6th gear positions) to cancel the control. Check that the vehicle restores the previous vehicle speed kept before the system deactivation when pushing up the RESUME/ACCELERATE switch at the vehicle speed approximately 40 km/h (25 MPH) or more. (M/T models)
- Drive the vehicle when the conventional (fixed speed) cruise control mode is set and shift the selector lever is in the "N" position to cancel the control. Check that the vehicle restores the previous vehicle speed kept before the system deactivation when shifting the selector lever is in the "D" position and pushing up the RESUME/ACCELERATE switch at the vehicle speed of approximately 40 km/h (25 MPH) or more. (A/T models)
- Drive the vehicle when the conventional (fixed speed) cruise control mode is set and press the CANCEL switch to cancel the control. Check that the vehicle restores the previous vehicle speed kept before the system deactivation when pushing up the RESUME/ACCELERATE switch at the vehicle speed of approximately 40 km/h (25 MPH) or more.

A
B
C
D
E
F
G
H
I
J
K
L
M
N
P

CCS

INSPECTION AND ADJUSTMENT

< BASIC INSPECTION >

[ICC]

>> INSPECTION END

SYSTEM DESCRIPTION

ICC

System Diagram

INFOID:000000005622516

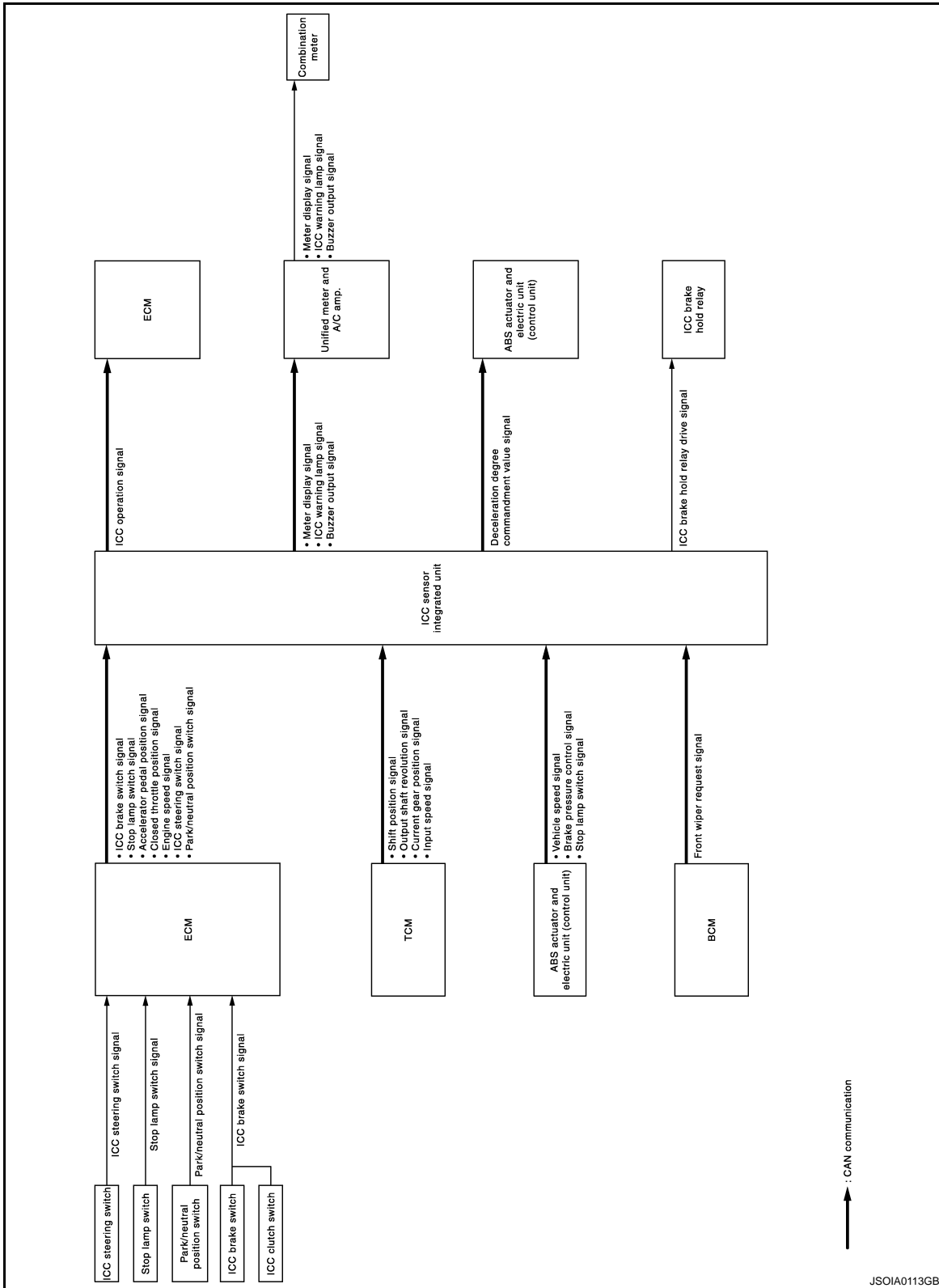

A
B
C
D
E
F
G
H
I
J
K
L
M
N
P

CCS

INFOID:000000005622517

< SYSTEM DESCRIPTION >

The Intelligent Cruise Control (ICC) system automatically maintains a selected distance from the vehicle traveling in front of own vehicle according to that vehicle's speed (up to the set speed), or at the set speed when the road ahead is clear.

The ICC system can be set to one of two cruise control modes:

CAUTION:

Never set the cruise speed exceeding the posted speed limit.

Vehicle-to-vehicle Distance Control Mode

For maintaining a selected distance between own vehicle and the vehicle in front of own vehicle up to the pre-set speed. Refer to [CCS-22, "System Description"](#).

Conventional (Fixed Speed) Cruise Control Mode

For cruising at a preset speed. Refer to [CCS-31, "System Description"](#).

NOTE:

In the Conventional (Fixed Speed) Cruise Control Mode, a warning chime will not sound to warn driver if own vehicle are too close to the vehicle ahead.

WARNING:

Always drive carefully and attentively when using either cruise control mode. To avoid serious injury or death, do not rely on the system to prevent accidents or to control the vehicle's speed in emergency situations. Do not use cruise control except in appropriate road and traffic conditions.

Brake Assist (With Preview Function)

Brake Assist (With Preview Function) share the systems and components with ICC system. Refer to [BRC-115, "System Description"](#).

ICC SENSOR INTEGRATED UNIT INPUT/OUTPUT SIGNAL ITEM

Input Signal Item

Transmit unit	Signal name	Description	
ECM	Accelerator pedal position signal	Receives the accelerator pedal position signal from ECM via CAN communication.	
	ICC steering switch signal	MAIN switch signal	Receives the ICC steering switch signal from ECM via CAN communication.
		SET/COAST switch signal	
		CANCEL switch signal	
		RESUME/ACCELERATE switch signal	
		DISTANCE switch signal	
	ICC brake switch signal	Receives the ICC brake switch signal from ECM via CAN communication.	
	Stop lamp switch signal	Receives the stop lamp switch signal from ECM via CAN communication.	
	Closed throttle position signal	Receives the closed throttle position signal from ECM via CAN communication.	
Engine speed signal	Receives the engine speed signal from ECM via CAN communication.		
	Park/neutral position switch signal*1	Receives park/neutral position switch signal from ECM with CAN communication.	
TCM*2	Shift position signal	Receives the shift position signal from TCM via CAN communication.	
	Output shaft revolution signal	Receives the output shaft revolution signal from TCM via CAN communication.	
	Current gear position signal	Receives the current gear position signal from TCM via CAN communication.	
	Input speed signal	Receives the input speed signal from TCM via CAN communication.	

< SYSTEM DESCRIPTION >

Transmit unit	Signal name	Description
ABS actuator and electric unit (control unit)	Vehicle speed signal	Receives the vehicle speed signal (wheel speed) from ABS actuator and electric unit (control unit) via CAN communication.
	Brake pressure control signal	Receives the brake pressure control signal from ABS actuator and electric unit (control unit) via CAN communication.
	Stop lamp switch signal	Receives the stop lamp switch signal from ABS actuator and electric unit (control unit) via CAN communication.
BCM	Front wiper request signal	Receives the front wiper request signal from BCM via CAN communication.

*1: M/T models

*2: A/T models

Output Signal Item

Reception unit	Signal name	Description
ECM	ICC operation signal	Transmits the ICC operation signal to ECM via CAN communication.
Combination meter (through unified meter and A/C amp.)	Own vehicle indicator signal	Transmits the meter display signal to the combination meter (through unified meter and A/C amp.) via CAN communication.
	Vehicle ahead detection indicator signal	
	Set vehicle speed indicator signal	
	Set distance indicator signal	
	MAIN switch indicator signal	
	SET switch indicator signal	
	ICC warning lamp signal	Transmits the ICC warning lamp signal to the combination meter (through unified meter and A/C amp.) via CAN communication.
	Buzzer output signal	Transmits the buzzer output signal to the combination meter (through unified meter and A/C amp.) via CAN communication.
ABS actuator and electric unit (control unit)	Deceleration degree commandment value signal	Transmits the deceleration degree commandment value signal to ABS actuator and electric unit (control unit) via CAN communication.
ICC brake hold relay	ICC brake hold relay drive signal	The ICC sensor integrated unit outputs the ICC brake hold relay drive signal and operates the ICC brake hold relay.

A
B
C
D
E
F
G
H
I
J
K
L
M
N
P



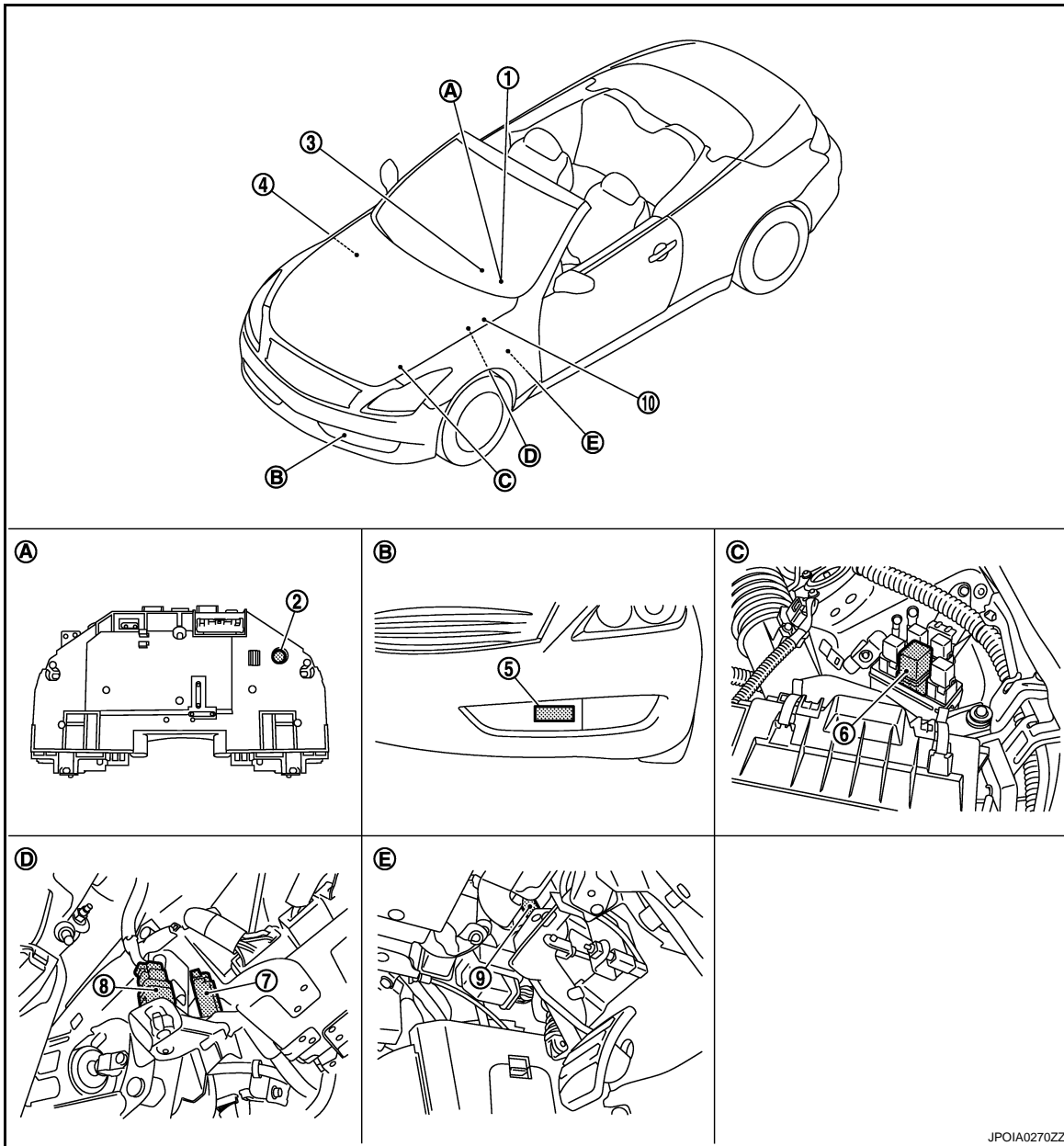

- | | | |
|--|-------------------------------|-------------------------|
| 1. Information display, ICC system warning lamp
(On the combination meter) | 2. Buzzer (ICC warning chime) | 3. ICC steering switch |
| 4. ECM
Refer to EC-26, "Component Parts Location" . | 5. ICC sensor integrated unit | 6. ICC brake hold relay |
| 7. ICC brake switch | 8. Stop lamp switch | 9. ICC clutch switch |
| 10. ABS actuator and electric unit (control unit)
Refer to BRC-11, "Component Parts Location" . | | |
| A. Back of the combination meter | B. Front bumper (LH) | C. Engine room (LH) |
| D. Upper side of brake pedal | E. Upper side clutch pedal | |

Component Description

INFOID:000000005622519

x: Applicable

Component	Function Description			Description
	*1	*2	*3	
ICC sensor integrated unit	x	x	x	Refer to CCS-43, "Description" .
ECM	x	x	x	Refer to CCS-70, "Description" .
ABS actuator and electric unit (control unit)	x	x	x	Refer to CCS-50, "Description" .
BCM	x			Transmits the front wiper request signal to ICC sensor integrated unit via CAN communication.
TCM	x	x		Refer to CCS-95, "Description" .
Unified meter and A/C amp.	x	x	x	Receives the meter display signal, buzzer output signal, and ICC warning lamp signal from ICC sensor integrated unit via CAN communication and transmits them to the combination meter via the communication line.
Combination meter	x	x	x	Performs the following operations using the signals received from the unified meter and A/C amp. via the communication line. <ul style="list-style-type: none"> • Displays the ICC system operation status using the meter display signal. • Illuminates the ICC system warning lamp using the ICC warning lamp signal. • Operates the buzzer (ICC warning chime) using the buzzer output signal.
ICC brake switch	x	x	x	Refer to CCS-52, "Description" .
Stop lamp switch	x	x	x	
ICC clutch switch	x	x	x	
ICC brake hold relay	x		x	Refer to CCS-64, "Description" .
Park/neutral position switch	x	x		Refer to CCS-103, "Description" .

*1: Vehicle-to-vehicle distance control mode

*2: Conventional (fixed speed) cruise control mode

*3: Brake Assist (With Preview Function)

A
B
C
D
E
F
G
H
I
J
K
L
M
N
P



VEHICLE-TO-VEHICLE DISTANCE CONTROL MODE FUNCTION

< SYSTEM DESCRIPTION >

[ICC]

VEHICLE-TO-VEHICLE DISTANCE CONTROL MODE FUNCTION

System Diagram

INFOID:000000005622520

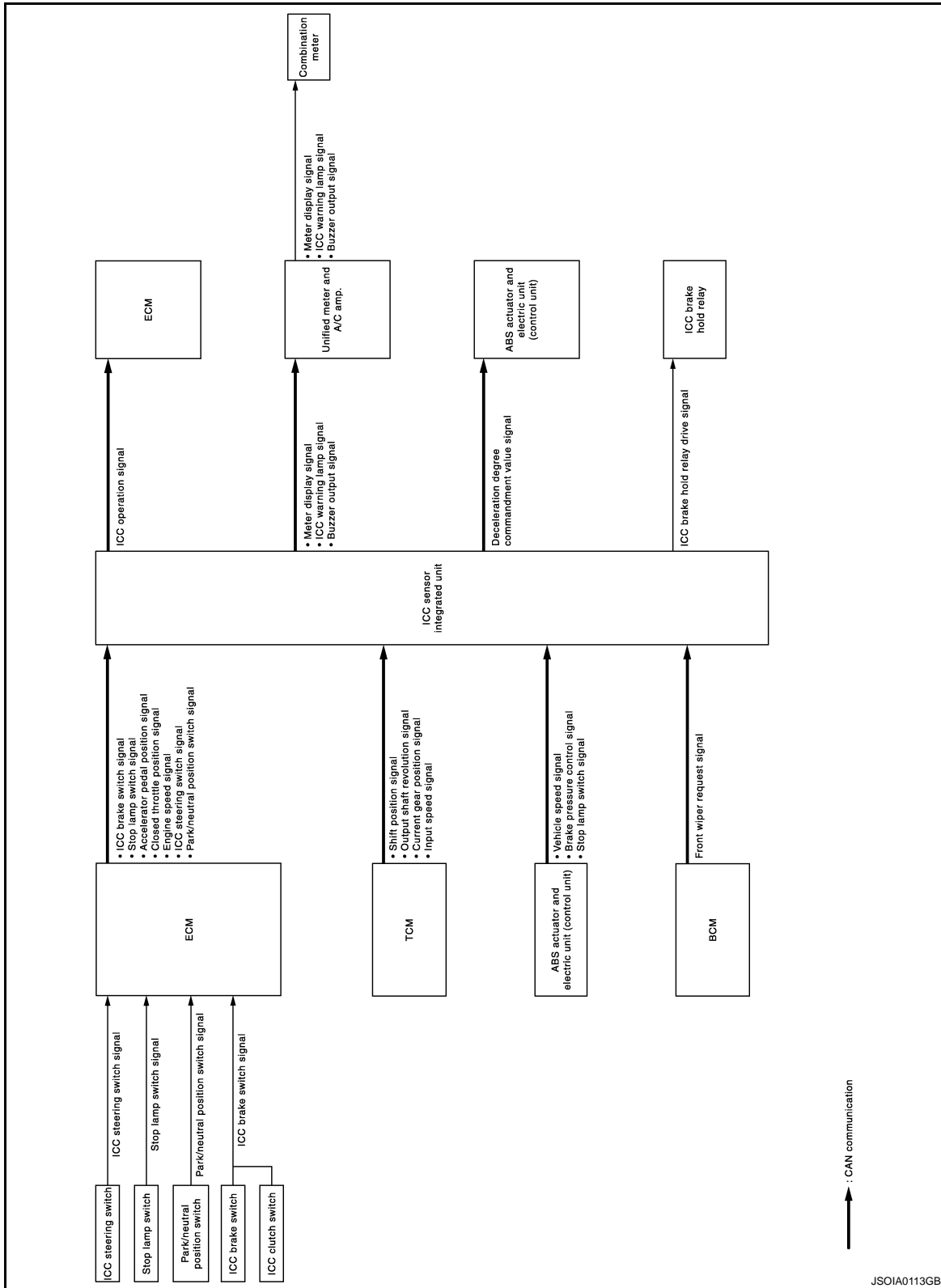

JSOIA0113GB

System Description

INFOID:000000005622521

FUNCTION DESCRIPTION

VEHICLE-TO-VEHICLE DISTANCE CONTROL MODE FUNCTION

[ICC]

< SYSTEM DESCRIPTION >

In the vehicle-to-vehicle distance control mode, the Intelligent Cruise Control (ICC) system automatically maintains a selected distance from the vehicle traveling in front of own vehicle according to that vehicle's speed (up to the set speed), or at the set speed when the road ahead is clear.

With ICC system, the driver can maintain the same speed as other vehicles without the constant need to adjust the set speed as driver would with a normal cruise control system.

The following items are controlled in the vehicle-to-vehicle distance control mode.

- When there are no vehicles traveling ahead, the vehicle-to-vehicle distance control mode maintains the speed set by the driver. The set speed range is between approximately 40 and 144 km/h (25 and 90 MPH).
- When there is a vehicle traveling ahead, the vehicle-to-vehicle distance control mode adjusts the speed to maintain the distance, selected by driver, from a vehicle ahead. The adjusting speed range is between approximately 32 km/h (20 MPH) and up to the set speed.
- When the vehicle traveling ahead has moved out from its lane of travel, the vehicle-to-vehicle distance control mode accelerates and maintains vehicle speed up to the set speed.

NOTE:

When the accelerator pedal is depressed, the brake operation and the warning are not performed by the ICC system.

OPERATION DESCRIPTION

Quickly push (less than 1.5seconds) and release the MAIN switch ON.

The MAIN switch indicator, set distance indicator, own vehicle indicator, and set vehicle speed indicator come on and ICC system is set to a standby state.

ICC sensor integrated unit performs the control as per the following:

Constant speed	Comparing the set vehicle speed with the current vehicle speed, transmit the command to ECM via CAN communication to reach the set vehicle speed, and controls the electric throttle control actuator.
Deceleration	When a vehicle ahead (slower than driver set vehicle speed) appears or when a vehicle ahead slows down, the system controls the electric throttle control actuator into the close direction and decelerates the vehicle. If greater deceleration is necessary, the system transmits the deceleration degree command value signal to the ABS actuator and electric unit (control unit) via CAN communication and operates the brake.
Following	The system controls the electric throttle control actuator and the brake fluid pressure to keep the proper distance between the vehicles according to the vehicle speed change of the vehicle ahead.
Acceleration	When a vehicle ahead is not detected because of it changes lanes or own vehicle changes lanes during the following driving, the system controls the electric throttle control actuator in the open direction and accelerates the vehicle to the set vehicle speed slowly.

Set Condition

Under a standby state, pushing down the SET/COAST switch will start system control.

- When vehicle speed is between approximately 40 km/h and 144 km/h (25 MPH and 90 MPH).

If the system is canceled by conditions 1-6 below, the system will resume control at the last set cruising speed by pushing up the RESUME/ACCELERATE switch.

NOTE:

- When the SET/COAST switch is pushed under the following conditions, the system cannot be set and the set speed indicator will blink for approximately 2 seconds.
 - When traveling below 40 km/h (25 MPH).
 - When the brakes are operated by the driver.
 - When the selector lever is not in the "D", "DS" position or manual mode. (A/T models)
 - When the clutch is operated by the driver. (M/T models)
 - When the shift knob is shifted in the neutral position. (M/T models)
 - When the front wipers are operating at LO or HI.
(If the vehicle is equipped with a rain sensing auto-wiper, the system may cancel when the wipers are set to INT.)

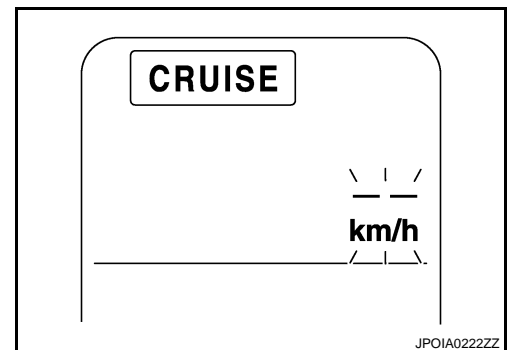

VEHICLE-TO-VEHICLE DISTANCE CONTROL MODE FUNCTION

[ICC]

< SYSTEM DESCRIPTION >

- When the SET/COAST switch is pushed under the following conditions, the system cannot be set. A warning chime will sound and the set speed indicator and own vehicle indicator will blink.
- When the VDC is OFF. (To use the ICC system, turn ON the VDC system, push the MAIN switch to turn OFF the ICC system and reset the ICC system by pushing the MAIN switch again.)
- When ABS or VDC (including the TCS) operates.
- When driving into a strong light (i.e., sunlight).
- When the wheel is slipping. (To use the ICC system, make sure the wheels are no longer spinning, push the MAIN switch to turn OFF the ICC system and reset the ICC system by pushing the MAIN switch again.)

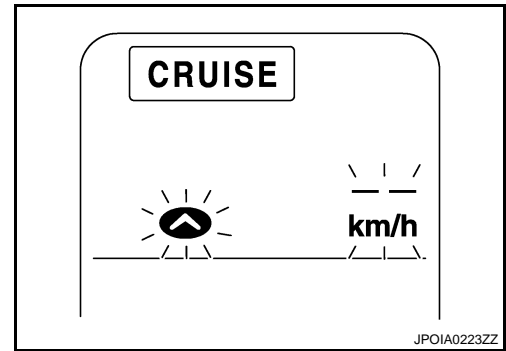

Cancel Conditions

1. When CANCEL switch is pressed.
2. When brake pedal is depressed.
3. When clutch pedal is depressed. (M/T models)
4. When the selector lever is not in the "D", "DS" position or manual mode. (A/T models)
5. When the shift knob is shifted in the neutral position. (M/T models)
6. When the vehicle speed falls below approximately 32 km/h (20 MPH).
7. When the front wipers are operating at LO or HI.
(If the vehicle is equipped with a rain sensing auto-wiper, the system may cancel when the wipers are set to INT.)
8. When ABS or VDC (including the TCS) operates.
9. When the MAIN switch is turned OFF.
10. When a wheel slips.
11. When driving into a strong light (i.e., sunlight).
12. When the VDC is turned OFF.
13. When the system malfunction occurs.

OPERATION AND DISPLAY

ICC Steering Switch

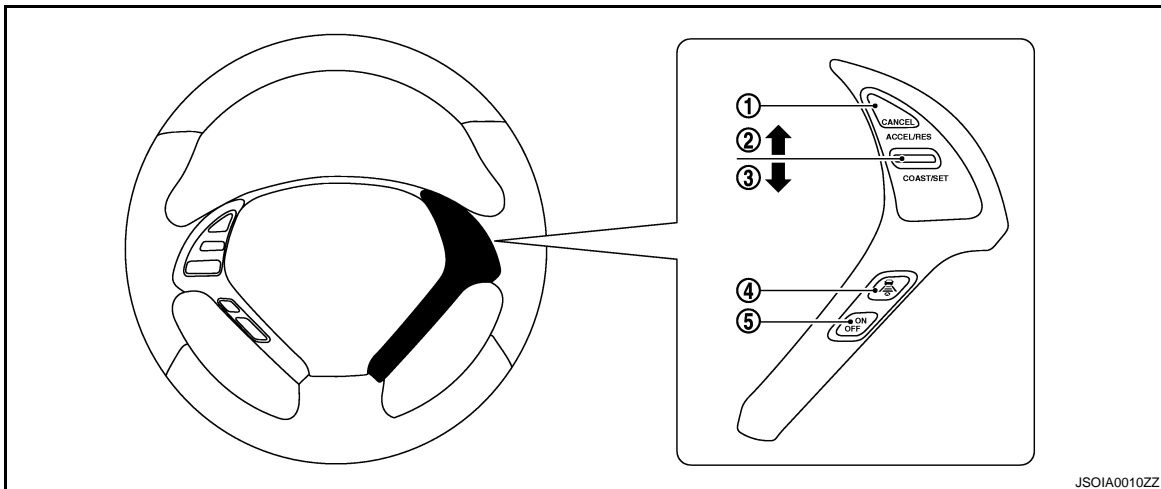

- | | | |
|--------------------|-----------------------------|---------------------|
| 1. CANCEL switch | 2. RESUME/ACCELERATE switch | 3. SET/COAST switch |
| 4. DISTANCE switch | 5. MAIN switch | |

No.	Switch name	Description
1	CANCEL switch	Deactivates the system without erasing the set speed.
2	RESUME/ACCELERATE switch	Resumes set speed or increases speed incrementally. <ul style="list-style-type: none"> • Push and hold the switch to increase the set speed by 5 km/h (5 MPH). • Push then quickly release the switch to increase the set speed by 1 km/h (1 MPH).

VEHICLE-TO-VEHICLE DISTANCE CONTROL MODE FUNCTION

< SYSTEM DESCRIPTION >

[ICC]

No.	Switch name	Description
3	SET/COAST switch	Sets desired cruise speed or reduces speed incrementally. <ul style="list-style-type: none"> • Push and hold the switch to decrease the set speed by 5 km/h (5 MPH). • Push then quickly release the switch to decrease the set speed by 1 km/h (1 MPH)
4	DISTANCE switch	Changes the following distance from: Long, Middle, Short.
5	MAIN switch	Master switch to activate the system (Press for less than 1.5 seconds).

ICC System Display (On The Information Display)

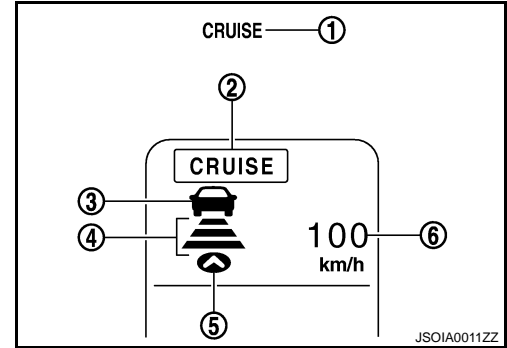

No.	Display item	Description
1	ICC system warning lamp	Indicates that a malfunction occurs in the ICC system.
2	MAIN switch indicator	Indicates that the MAIN switch is ON (ICC system ON).
3	Vehicle ahead detection indicator	Indicates whether it detects a vehicle ahead.
4	Set distance indicator	Indicates the selected distance between vehicles set with the DISTANCE switch.
5	Own vehicle indicator	Indicates the own vehicle.
6	Set vehicle speed indicator	Indicates the set vehicle speed.

System Control Condition Display

Quickly push (less than 1.5 seconds) and release the MAIN switch ON.

The MAIN switch indicator (cruise indicator), set distance indicator, own vehicle indicator, and set vehicle speed indicator come on and ICC system is set to a standby state.

Condition	Display on ICC system display
Standby mode	<p>The diagram shows the ICC system display in standby mode. It features a 'CRUISE' indicator at the top, an own vehicle indicator (a car icon) in the center, and a set vehicle speed indicator (a dashed line and 'km/h') on the right. The diagram is labeled 'JPOIA0141ZZ' at the bottom right.</p>

A
B
C
D
E
F
G
H
I
J
K
L
M
N
P

CCS

VEHICLE-TO-VEHICLE DISTANCE CONTROL MODE FUNCTION

< SYSTEM DESCRIPTION >

[ICC]

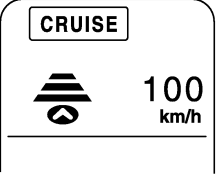
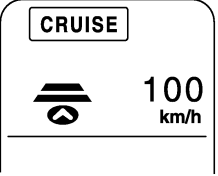
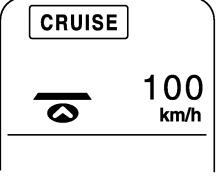
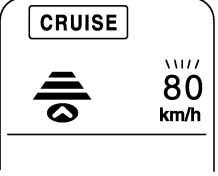
		Condition	Display on ICC system display
Control mode	Without a vehicle ahead	Set vehicle distance (Long)	 <p>JPOIA0142ZZ</p>
		Set vehicle distance (Middle)	 <p>JPOIA0143ZZ</p>
		Set vehicle distance (Short)	 <p>JPOIA0144ZZ</p>
		When the vehicle speed exceeds the set speed	 <p>JPOIA0145ZZ</p>

VEHICLE-TO-VEHICLE DISTANCE CONTROL MODE FUNCTION

< SYSTEM DESCRIPTION >

[ICC]

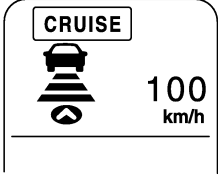
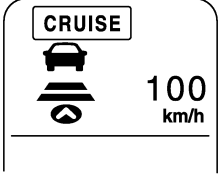
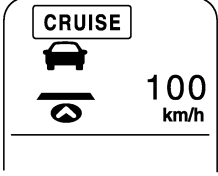
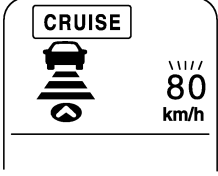
		Condition	Display on ICC system display
Control mode	With a vehicle ahead	Set vehicle distance (Long)	 JPOIA0146ZZ
		Set vehicle distance (Middle)	 JPOIA0147ZZ
		Set vehicle distance (Short)	 JPOIA0148ZZ
		When the vehicle speed exceeds the set speed	 JPOIA0149ZZ

Approach Warning Display

If own vehicle comes closer to a vehicle ahead due to rapid deceleration of that vehicle or if another vehicle cuts in, the system warns the driver with the chime and ICC system display. Decelerate by depressing the brake pedal to maintain a safe vehicle distance if:

- The chime sounds.
- The vehicle ahead detection indicator and set distance indicator blink.

The warning chime may not sound in some cases when there is a short distance between vehicles. Some examples are:

- When the vehicles are traveling at the same speed and the distance between vehicles is not changing.
- When the vehicle ahead is traveling faster and the distance between vehicles is increasing.
- When a vehicle cuts in at near own vehicle.

The warning chime will not sound when own vehicle approaches vehicles that are parked or moving slowly.

The warning chime will not sound when the accelerator pedal is depressed, overriding the system.

The approach warning chime may sound and the system display may blink when the ICC sensor detects some reflectors which are fitted on vehicles in other lanes or on the side of the road.

This may cause the ICC system to decelerate or accelerate the vehicle.

The ICC sensor may detect these reflectors when the vehicle is driven on winding roads, hilly roads or when entering or exiting a curve.

The ICC sensor may also detect reflectors on narrow roads or in road construction zones.

In these cases driver will have to manually control the proper distance ahead of own vehicle.

Also, the sensor sensitivity can be affected by vehicle operation (steering maneuver or driving position in the lane) or traffic or vehicle condition (for example, if a vehicle is being driven with some damage).

A
B
C
D
E
F
G
H
I
J
K
L
M
N
P

CCS

VEHICLE-TO-VEHICLE DISTANCE CONTROL MODE FUNCTION

< SYSTEM DESCRIPTION >

[ICC]

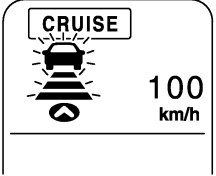
Condition	Display on ICC system display
<p>When own vehicle comes closer to the vehicle ahead and it is judged that the distance between the vehicles is not sufficient</p>	 <p style="text-align: right; font-size: small;">JPOIA0150ZZ</p>

Warning Lamp and Automatic Cancellation Display

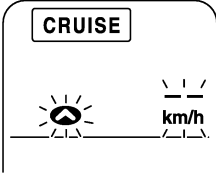
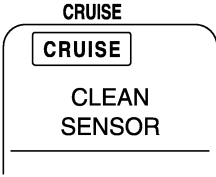
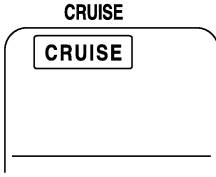
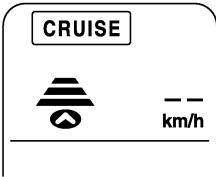
	Condition	Description	Display on ICC system display
Warning display	<ul style="list-style-type: none"> When the VDC is turned OFF When the VDC or ABS (including the TCS) operates When a wheel slips When driving into a strong light (i.e., sunlight) 	<p>A chime sounds and the control is automatically canceled.</p> <p>NOTE: When the conditions listed above are no longer present, turn the system OFF using the MAIN switch. Turn the ICC system back on to use the system.</p>	 <p style="text-align: right; font-size: small;">JPOIA0151ZZ</p>
	<p>When the sensor window is dirty, making it impossible to detect a vehicle ahead.</p>	<p>A chime sounds and the control is automatically canceled.</p> <p>NOTE: Park the vehicle in a safe place, turn the engine OFF. Clean the sensor window with a soft cloth and then perform the settings again.</p>	 <p style="text-align: right; font-size: small;">JPOIA0152ZZ</p>
	<p>When the ICC system is malfunctioning</p>	<p>A chime sounds and the control is automatically canceled.</p> <p>NOTE: Turn the engine OFF and restart engine. If there is no malfunction, it is possible to set the system.</p>	 <p style="text-align: right; font-size: small;">JPOIA0153ZZ</p>
Automatic cancellation display	<ul style="list-style-type: none"> When brake pedal is depressed When clutch pedal is depressed (M/T models) When CANCEL switch is pressed When the vehicle speed falls below approximately 32 km/h (20 MPH) When the selector lever is not in "D", "DS" position or manual mode (A/T models) When the shift knob is shifted in the neutral position (M/T models) When the front wipers are operating at LO or HI (If the vehicle is equipped with a rain sensing auto-wiper, the system may cancel when the wipers are set to INT) 	<p>A chime sounds and the control is automatically canceled.</p> <p>NOTE:</p> <ul style="list-style-type: none"> The system will be in a standby, after the control is automatically canceled. A chime sounds when the control is automatically canceled, except when brake pedal is depressed or when CANCEL switch is pressed. 	 <p style="text-align: right; font-size: small;">JPOIA0154ZZ</p>

NOTE:

VEHICLE-TO-VEHICLE DISTANCE CONTROL MODE FUNCTION

[ICC]

< SYSTEM DESCRIPTION >

When the ICC system is automatically canceled, the cancellation condition can be displayed on "WORK SUPPORT" of CONSULT-III (ICC).

Component Parts Location

INFOID:000000005622522

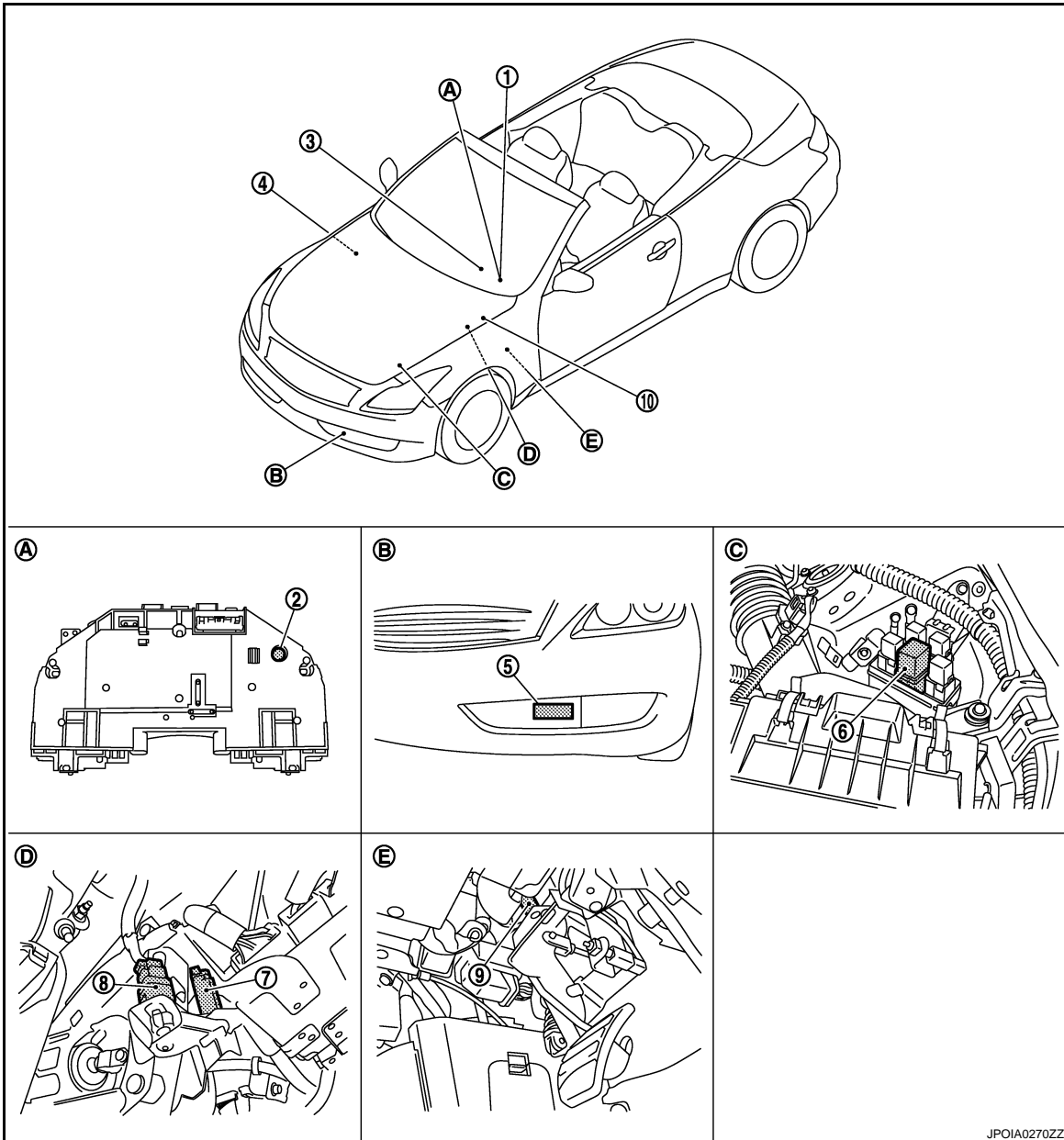

- | | | |
|--|-------------------------------|-------------------------|
| 1. Information display, ICC system warning lamp
(On the combination meter) | 2. Buzzer (ICC warning chime) | 3. ICC steering switch |
| 4. ECM
Refer to EC-26, "Component Parts Location" . | 5. ICC sensor integrated unit | 6. ICC brake hold relay |
| 7. ICC brake switch | 8. Stop lamp switch | 9. ICC clutch switch |
| 10. ABS actuator and electric unit (control unit)
Refer to BRC-11, "Component Parts Location" . | | |
| A. Back of the combination meter | B. Front bumper (LH) | C. Engine room (LH) |
| D. Upper side of brake pedal | E. Upper side clutch pedal | |

JPOIA0270ZZ

A
B
C
D
E
F
G
H
I
J
K
L
M
N

CCS

P

VEHICLE-TO-VEHICLE DISTANCE CONTROL MODE FUNCTION

< SYSTEM DESCRIPTION >

[ICC]

Component Description

INFOID:000000005622523

×: Applicable

Component	Function Description			Description
	*1	*2	*3	
ICC sensor integrated unit	×	×	×	Refer to CCS-43. "Description" .
ECM	×	×	×	Refer to CCS-70. "Description" .
ABS actuator and electric unit (control unit)	×	×	×	Refer to CCS-50. "Description" .
BCM	×			Transmits the front wiper request signal to ICC sensor integrated unit via CAN communication.
TCM	×	×		Refer to CCS-95. "Description" .
Unified meter and A/C amp.	×	×	×	Receives the meter display signal, buzzer output signal, and ICC warning lamp signal from ICC sensor integrated unit via CAN communication and transmits them to the combination meter via the communication line.
Combination meter	×	×	×	Performs the following operations using the signals received from the unified meter and A/C amp. via the communication line. <ul style="list-style-type: none"> • Displays the ICC system operation status using the meter display signal. • Illuminates the ICC system warning lamp using the ICC warning lamp signal. • Operates the buzzer (ICC warning chime) using the buzzer output signal.
ICC brake switch	×	×	×	Refer to CCS-52. "Description" .
Stop lamp switch	×	×	×	
ICC clutch switch	×	×	×	
ICC brake hold relay	×		×	Refer to CCS-64. "Description" .
Park/neutral position switch	×	×		Refer to CCS-103. "Description" .

*1: Vehicle-to-vehicle distance control mode

*2: Conventional (fixed speed) cruise control mode

*3: Brake Assist (With Preview Function)

CONVENTIONAL (FIXED SPEED) CRUISE CONTROL MODE FUNCTION

[ICC]

< SYSTEM DESCRIPTION >

CONVENTIONAL (FIXED SPEED) CRUISE CONTROL MODE FUNCTION

System Diagram

INFOID:000000005622524

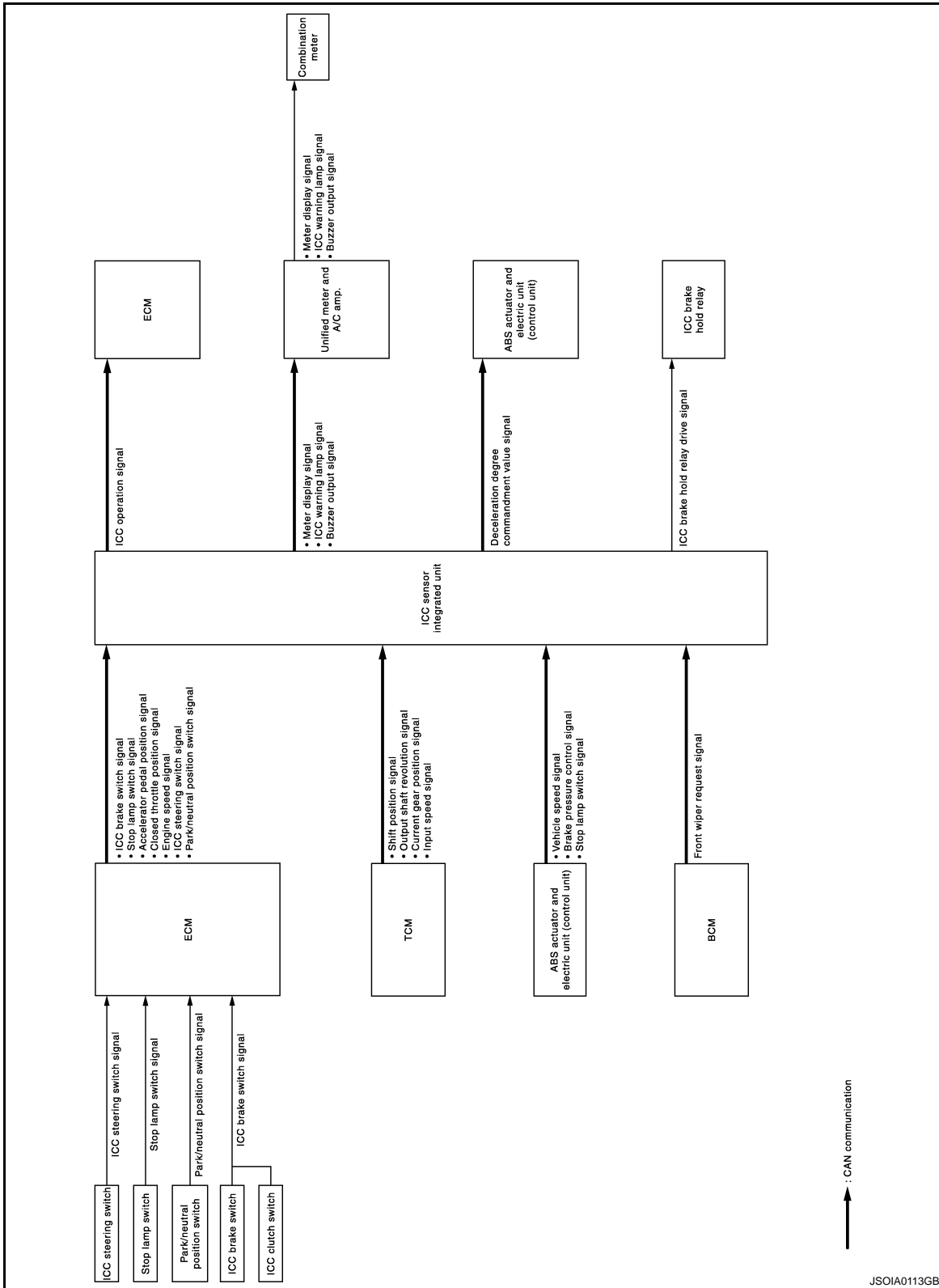

A
B
C
D
E
F
G
H
I
J
K
L
M
N
P

CCS

System Description

INFOID:000000005622525

FUNCTION DESCRIPTION

CONVENTIONAL (FIXED SPEED) CRUISE CONTROL MODE FUNCTION

< SYSTEM DESCRIPTION >

[ICC]

This mode allows driving at a speed between 40 to 144 km/h (25 to 90 MPH) without keeping foot on the accelerator pedal.

NOTE:

In the conventional (fixed speed) cruise control mode, a warning chime does not sound to warn driver if own vehicle are too close to the vehicle ahead, as neither the presence of the vehicle ahead nor the vehicle-to-vehicle distance is detected.

OPERATION DESCRIPTION

To turn ON the conventional (fixed speed) cruise control mode, push and hold the MAIN switch for longer than approximately 1.5 seconds when ICC system is OFF.

When pushing the MAIN switch ON, the ICC system display and the MAIN switch indicator are displayed on the information display.

After hold the MAIN switch ON for longer than approximately 1.5 seconds, the ICC system display goes out.

The MAIN switch indicator stays lit and brings the system to standby state.

NOTE:

To turn on the vehicle-to-vehicle distance control mode again, turn OFF the system and quickly push (less than 1.5 seconds) the MAIN switch.

ICC sensor integrated unit performs the control as per the following:

Constant speed	Comparing the set vehicle speed with the current vehicle speed, transmits the command to ECM via CAN communication to reach the set vehicle speed, and controls the electronic throttle control actuator.
----------------	---

Set Condition

When the system is under a standby state and the vehicle speed is between approximately 40 to 144 km/h (25 to 90 MPH), pushing the SET/COAST switch will start system control.

If the system is canceled by conditions 1-7 below, the system will resume control at the last set cruising speed by pushing the RESUME/ACCELERATE switch.

Cancel conditions

1. When CANCEL switch is pressed.
2. When brake pedal is depressed.
3. When clutch pedal is depressed. (M/T models)
4. When the vehicle speed falls below approximately 32 km/h (20 MPH).
5. When the vehicle slows down more than 13 km/h (8 MPH) below the set speed.
6. When the selector lever is not in the "D", "DS" position or manual mode. (A/T models)
7. When the shift knob is shifted in the neutral position. (M/T models)
8. When the MAIN switch is turned OFF.
9. When VDC (including the TCS) operates.
10. When a wheel slips.
11. When the system malfunction occurs.

OPERATION AND DISPLAY

ICC Steering Switch

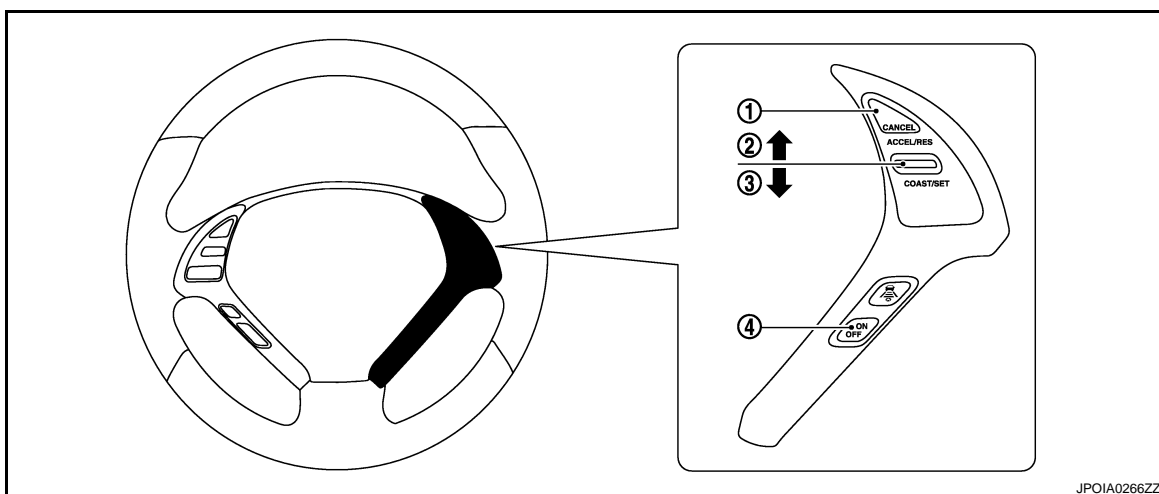

JPOIA0266ZZ

CONVENTIONAL (FIXED SPEED) CRUISE CONTROL MODE FUNCTION

< SYSTEM DESCRIPTION >

[ICC]

- | | | |
|------------------|-----------------------------|---------------------|
| 1. CANCEL switch | 2. RESUME/ACCELERATE switch | 3. SET/COAST switch |
| 4. MAIN switch | | |

No.	Description	Function
1	CANCEL switch	Deactivates system without erasing set speed.
2	RESUME/ACCELERATE switch	Resumes set speed or increases speed incrementally.
3	SET/COAST switch	Sets desired cruise speed or reduces speed incrementally.
4	MAIN switch	Master switch to activate the system (Press for more than 1.5 seconds).

ICC System Display (On The Information Display)

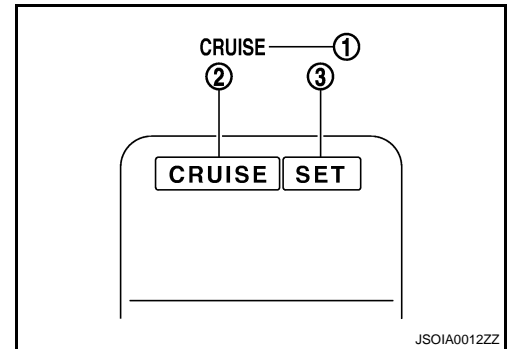

No.	Description	Function
1	ICC system warning lamp	Indicates that a malfunction occurs in the ICC system.
2	MAIN switch indicator	Indicates that the MAIN switch is ON (ICC system ON).
3	SET switch indicator	Indicates that the set conventional (fixed speed) cruise control mode is controlled.

System Control Condition Display

Push and hold the MAIN switch for longer than approximately 1.5 seconds. This mode will be in a standby state for setting.

Condition	Display on ICC system display
Standby mode	<p>The diagram shows a rectangular display area with a single box labeled 'CRUISE' at the top. Below the box is a horizontal line. The diagram is labeled 'JPOIA0158ZZ' in the bottom right corner.</p>
Control mode	<p>The diagram shows a rectangular display area with two boxes: 'CRUISE' on the left and 'SET' on the right. Below the boxes is a horizontal line. The diagram is labeled 'JPOIA0156ZZ' in the bottom right corner.</p>

Warning and Automatic Cancellation Display

A
B
C
D
E
F
G
H
I
J
K
L
M
N
P

CCS

CONVENTIONAL (FIXED SPEED) CRUISE CONTROL MODE FUNCTION

< SYSTEM DESCRIPTION >

[ICC]

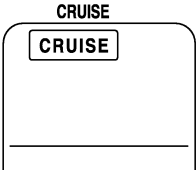
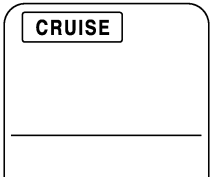
	Condition	Description	Display on ICC system display
Warning display	When the ICC system is malfunctioning	<p>A chime sounds and the control is automatically canceled.</p> <p>NOTE: Turn the engine OFF and restart engine. If there is no malfunction, it is possible to set the system.</p>	 <p style="text-align: right; font-size: small;">JPOIA0157ZZ</p>
System cancel display	<ul style="list-style-type: none"> • When brake pedal is depressed • When pressing CANCEL switch • When clutch pedal depressed (M/T models) • When the vehicle speed falls below approximately 32 km/h (20 MPH) • When the vehicle slows down more than 13 km/h (8 MPH) below the set speed • When the selector lever is not in the "D", "DS" position or manual mode (A/T models) • When the shift knob is shifted in the neutral position (M/T models) • When VDC (including the TCS) operates • When a wheel slips 	<p>A chime sounds and the control is automatically canceled.</p> <p>NOTE:</p> <ul style="list-style-type: none"> • The system will be in a standby, after the control is automatically canceled. • A chime sounds when the control is automatically canceled, except when brake pedal is depressed or when CANCEL switch is pressed. 	 <p style="text-align: right; font-size: small;">JPOIA0158ZZ</p>

NOTE:

When the ICC system is automatically canceled, the cancellation condition can be displayed on "WORK SUPPORT" of CONSULT-III (ICC).

CONVENTIONAL (FIXED SPEED) CRUISE CONTROL MODE FUNCTION

< SYSTEM DESCRIPTION >

[ICC]

Component Parts Location

INFOID:000000005622526

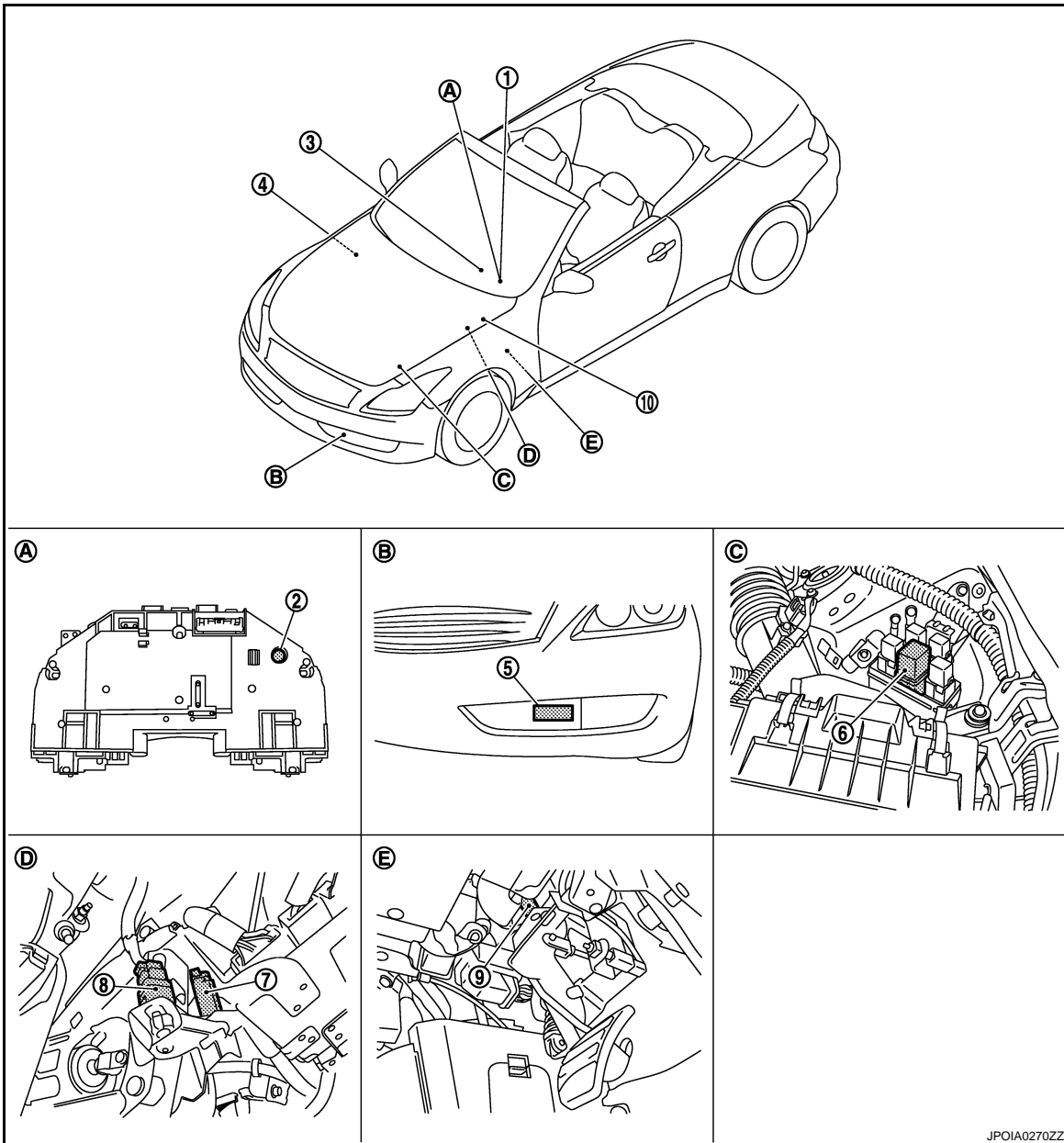

- | | | |
|--|-------------------------------|-------------------------|
| 1. Information display, ICC system warning lamp
(On the combination meter) | 2. Buzzer (ICC warning chime) | 3. ICC steering switch |
| 4. ECM
Refer to EC-26, "Component Parts Location" . | 5. ICC sensor integrated unit | 6. ICC brake hold relay |
| 7. ICC brake switch | 8. Stop lamp switch | 9. ICC clutch switch |
| 10. ABS actuator and electric unit (control unit)
Refer to BRC-11, "Component Parts Location" . | | |
| A. Back of the combination meter | B. Front bumper (LH) | C. Engine room (LH) |
| D. Upper side of brake pedal | E. Upper side clutch pedal | |

A
B
C
D
E
F
G
H
I
J
K
L
M
N
P

CCS

CONVENTIONAL (FIXED SPEED) CRUISE CONTROL MODE FUNCTION

< SYSTEM DESCRIPTION >

[ICC]

Component Description

INFOID:000000005622527

×: Applicable

Component	Function Description			Description
	*1	*2	*3	
ICC sensor integrated unit	×	×	×	Refer to CCS-43. "Description" .
ECM	×	×	×	Refer to CCS-70. "Description" .
ABS actuator and electric unit (control unit)	×	×	×	Refer to CCS-50. "Description" .
BCM	×			Transmits the front wiper request signal to ICC sensor integrated unit via CAN communication.
TCM	×	×		Refer to CCS-95. "Description" .
Unified meter and A/C amp.	×	×	×	Receives the meter display signal, buzzer output signal, and ICC warning lamp signal from ICC sensor integrated unit via CAN communication and transmits them to the combination meter via the communication line.
Combination meter	×	×	×	Performs the following operations using the signals received from the unified meter and A/C amp. via the communication line. <ul style="list-style-type: none"> Displays the ICC system operation status using the meter display signal. Illuminates the ICC system warning lamp using the ICC warning lamp signal. Operates the buzzer (ICC warning chime) using the buzzer output signal.
ICC brake switch	×	×	×	Refer to CCS-52. "Description" .
Stop lamp switch	×	×	×	
ICC clutch switch	×	×	×	
ICC brake hold relay	×		×	Refer to CCS-64. "Description" .
Park/neutral position switch	×	×		Refer to CCS-103. "Description" .

*1: Vehicle-to-vehicle distance control mode

*2: Conventional (fixed speed) cruise control mode

*3: Brake Assist (With Preview Function)

DIAGNOSIS SYSTEM (ICC SENSOR INTEGRATED UNIT)

< SYSTEM DESCRIPTION >

[ICC]

DIAGNOSIS SYSTEM (ICC SENSOR INTEGRATED UNIT)

Diagnosis Description

INFOID:000000005622528

The DTC is displayed on the information display by operating the ICC steering switch.

ON BOARD SELF-DIAGNOSIS SYSTEM DIAGRAM

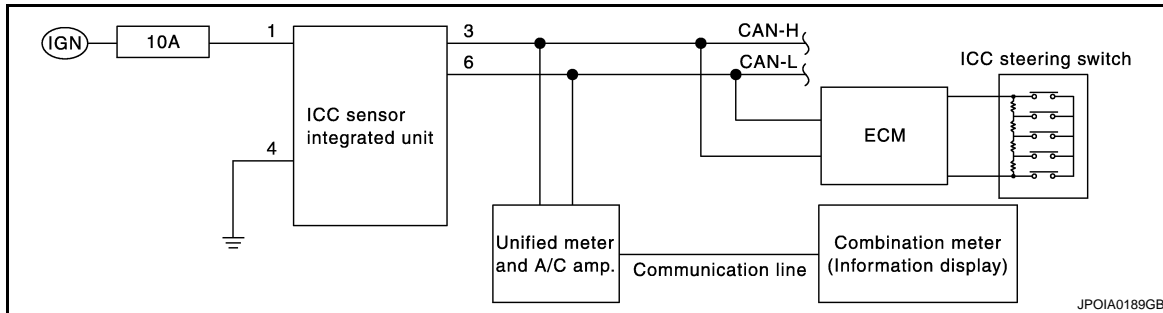

ON BOARD SELF-DIAGNOSIS OPERATION PROCEDURE

CAUTION:

Start condition of on board self-diagnosis

- MAIN switch OFF
- Vehicle speed 0 km/h (0 MPH)

1. Turn the ignition switch OFF.
2. Start the engine.
3. Wait for 5 seconds after starting the engine. Push up the RESUME/ACCELERATE switch 5 times and push down the SET/COAST switch 5 times within 10 seconds.

NOTE:

If the above operation cannot be performed within 10 seconds after waiting for 5 seconds after starting the engine, repeat the procedure from step 1.

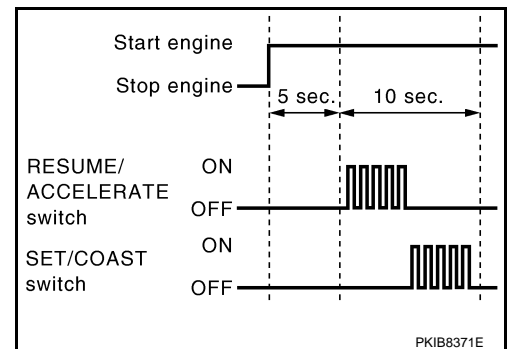

4. The DTC is displayed on the set vehicle speed indicator (1) on the ICC system display on the information display when the on board self-diagnosis starts. Refer to [CCS-116, "DTC Index"](#).

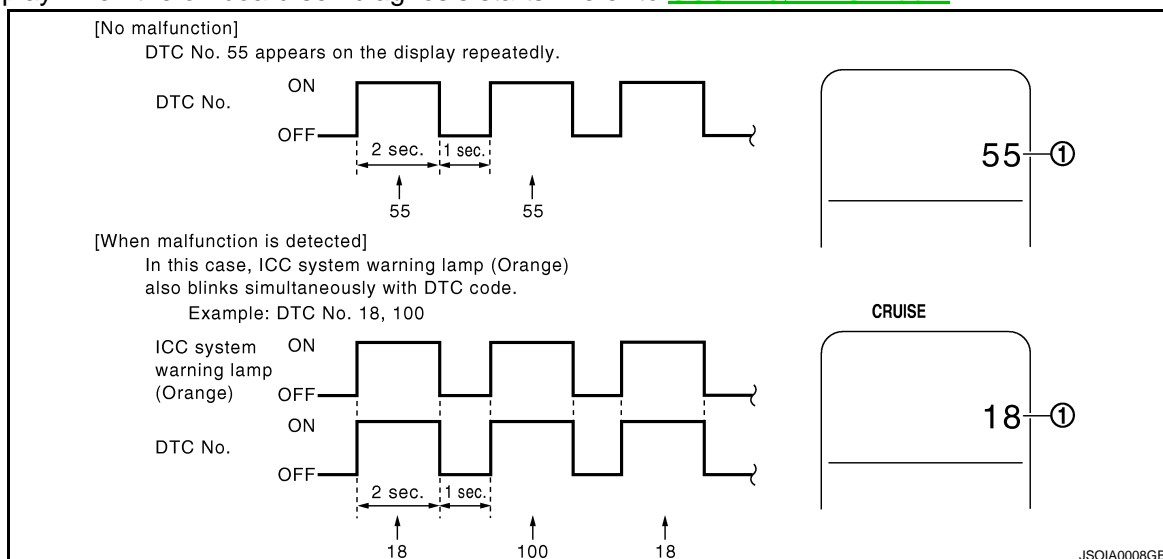

NOTE:

- It displays for up to 5 minutes and then stops.

DIAGNOSIS SYSTEM (ICC SENSOR INTEGRATED UNIT)

[ICC]

< SYSTEM DESCRIPTION >

- If multiple malfunctions exist, up to 3 DTCs can be stored in memory at the most, and the most recent one is displayed first.

WHEN THE ON BOARD SELF-DIAGNOSIS DOES NOT START

If the on board self-diagnosis does not start, check the following items.

Assumed abnormal part		Inspection item
ICC system display	Combination meter malfunction	Check that the self-diagnosis function of the combination meter operates. Refer to MWI-33, "Diagnosis Description" .
	Unified meter and A/C amp. malfunction	Check power supply and ground circuit of unified meter and A/C amp. Refer to MWI-48, "UNIFIED METER AND A/C AMP. : Diagnosis Procedure" .
	Communication error of the combination meter and the unified meter and A/C amp.	Start the self-diagnosis of the unified meter and A/C amp. and then check the self-diagnosis results. Refer to MWI-102, "DTC Index" .
ICC steering switch malfunction	Perform the inspection for DTC "C1A06". Refer to CCS-60, "Diagnosis Procedure" .	
Harness malfunction between ICC steering switch and ECM		
ECM malfunction		
ICC sensor integrated unit malfunction		<ul style="list-style-type: none"> • Check power supply and ground circuit of ICC sensor integrated unit. Refer to CCS-102, "Diagnosis Procedure". • Perform SELF-DIAGNOSIS for "ICC" with CONSULT-III, and then check the malfunctioning parts. Refer to CCS-116, "DTC Index".

HOW TO ERASE ON BOARD SELF-DIAGNOSIS

1. Turn the ignition switch OFF.
2. Start the engine, and then start the on board self-diagnosis.
3. Press the CANCEL switch 5 times, and then press the DISTANCE switch 5 times under the condition that the on board self-diagnosis starts.

NOTE:

- Complete the operation within 10 seconds after pressing the CANCEL switch first.
- If the operation is not completed within 10 seconds, repeat the procedure from step 1.

4. DTC 55 is displayed after erasing.

NOTE:

DTCs for existing malfunction can not be erased.

5. Turn ignition switch OFF, and finish the diagnosis.

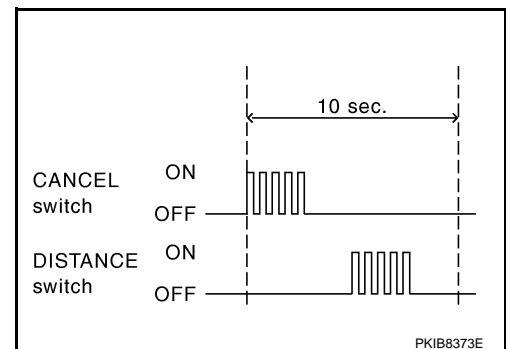

CONSULT-III Function (ICC)

INFOID:000000005622529

DESCRIPTION

CONSULT-III performs the following functions via CAN communication using ICC sensor integrated unit.

Diagnosis mode	Description
Work Support	<ul style="list-style-type: none"> • It can monitor the adjustment direction indication in order to perform the laser beam aiming operation smoothly. • Displays causes of automatic cancellation of the ICC system.
Self Diagnostic Result	Displays malfunctioning system memorized in ICC sensor integrated unit.
Data Monitor	Displays real-time input/output data of ICC sensor integrated unit.
Active Test	Enables operation check of electrical loads by transmitting driving signal to them.
Ecu Identification	Displays ICC sensor integrated unit part number.
CAN Diag Support Monitor	The results of transmit/receive diagnosis of CAN communication can be read.

DIAGNOSIS SYSTEM (ICC SENSOR INTEGRATED UNIT)

< SYSTEM DESCRIPTION >

[ICC]

WORK SUPPORT

Work support items	Description
CAUSE OF AUTO-CANCEL	Displays causes of automatic cancellation of the ICC system.
LASER BEAM ADJUST	Outputs laser beam, calculates dislocation of the beam, and indicates adjustment direction.

Display Items for The Cause of Automatic Cancellation

NOTE:

- Causes of the maximum five cancellations (system cancel) are displayed.
- The displayed cancellation causes display the number of the ignition switch ON/OFF up to 254. It is fixed to 254 if it is over 254. It returns to 0 when the same cancellation cause is detected again.

×: Applicable

Cause of cancellation	Vehicle-to-vehicle distance control mode	Conventional (fixed speed) cruise control mode	Description
OPERATING WIPER	×		The wiper operates at HI or LO (it includes when the wiper is operated at LO or HI with the wiper switch INT position)
OPERATING ABS	×		ABS function was operated
OPERATING TCS	×	×	TCS function was operated
OPERATING VDC	×	×	VDC function was operated
ECM CIRCUIT	×	×	ECM did not permit ICC operation
OPE SW VOLT CIRC	×	×	The ICC steering switch input voltage is not within standard range
LASER SUNBEAM	×		Intense light such as sunlight entered ICC sensor integrated unit light sensing part
LASER TEMP	×		Temperature around ICC sensor integrated unit became low
OP SW DOUBLE TOUCH	×	×	ICC steering switches were pressed at the same time
WHL SPD ELEC NOISE	×	×	Wheel speed sensor signal caught electromagnetic noise
VDC/TCS OFF SW	×		VDC OFF switch was pressed
VHCL SPD UNMATCH	×	×	Wheel speed became different from A/T vehicle speed
TIRE SLIP	×	×	Wheel slipped
IGN LOW VOLT	×	×	Power supply voltage became low
WHEEL SPD UNMATCH	×	×	The wheel speeds of 4 wheels are out of the specified values
VHCL SPD DOWN	×	×	Vehicle speed becomes 32 km/h (20 MPH) and under
CAN COMM ERROR	×	×	ICC sensor integrated unit received an abnormal signal with CAN communication
ABS/TCS/VDC CIRC	×	×	An abnormal condition occurs in VDC/TCS/ABS system
ECD CIRCUIT	×		An abnormal condition occurs in ECD system
ENG SPEED DOWN	×	×	Engine speed became extremely low while controlling ICC system
ASCD VHCL SPD DTAC		×	Vehicle speed is detached from set vehicle speed
ASCD DOUBLE COMD		×	Cancel switch and operation switch are detected simultaneously
NO RECORD	×	×	-

Laser Beam Adjust

Refer to [CCS-6, "LASER BEAM AIMING ADJUSTMENT : Description"](#).

SELF DIAGNOSTIC RESULT

Refer to [CCS-116, "DTC Index"](#).

DATA MONITOR

DIAGNOSIS SYSTEM (ICC SENSOR INTEGRATED UNIT)

< SYSTEM DESCRIPTION >

[ICC]

×: Applicable

Monitored item [Unit]	MAIN SIGNAL	Description
MAIN SW [On/Off]	×	Indicates [On/Off] status as judged from ICC steering switch signal (ECM transmits ICC steering switch signal through CAN communication).
SET/COAST SW [On/Off]	×	Indicates [On/Off] status as judged from ICC steering switch signal (ECM transmits ICC steering switch signal through CAN communication).
CANCEL SW [On/Off]	×	Indicates [On/Off] status as judged from ICC steering switch signal (ECM transmits ICC steering switch signal through CAN communication).
RESUME/ACC SW [On/Off]	×	Indicates [On/Off] status as judged from ICC steering switch signal (ECM transmits ICC steering switch signal through CAN communication).
DISTANCE SW [On/Off]		Indicates [On/Off] status as judged from ICC steering switch signal (ECM transmits ICC steering switch signal through CAN communication).
CRUISE OPE [On/Off]	×	Indicates whether controlling or not (ON means "controlling").
BRAKE SW [On/Off]	×	Indicates [On/Off] status as judged from ICC brake switch signal (ECM transmits ICC brake switch signal through CAN communication).
STOP LAMP SW [On/Off]	×	Indicates [On/Off] status as judged from stop lamp switch signal (ECM transmits stop lamp switch signal through CAN communication).
IDLE SW [On/Off]		Indicates [On/Off] status of idle switch read from ICC sensor integrated unit through CAN communication (ECM transmits On/Off status through CAN communication).
SET DISTANCE [Short/Mid/Long]	×	Indicates set distance memorized in ICC sensor integrated unit.
CRUISE LAMP [On/Off]	×	Indicates [On/Off] status of MAIN switch indicator output.
OWN VHCL [On/Off]		Indicates [On/Off] status of own vehicle indicator output.
VHCL AHEAD [On/Off]		Indicates [On/Off] status of vehicle ahead detection indicator output.
ICC WARNING [On/Off]		Indicates [On/Off] status of ICC system warning lamp output.
VHCL SPEED SE [km/h] or [mph]	×	Indicates vehicle speed calculated from ICC sensor integrated unit through CAN communication [ABS actuator and electric unit (control unit) transmits vehicle speed signal (wheel speed) through CAN communication].
SET VHCL SPD [km/h] or [mph]	×	Indicates set vehicle speed memorized in ICC sensor integrated unit.
BUZZER O/P [On/Off]		Indicates [On/Off] status of ICC warning chime output.
THRTL SENSOR [deg]	×	NOTE: The item is displayed, but it is not monitored.
ENGINE RPM [rpm]		Indicates engine speed read from ICC sensor integrated unit through CAN communication (ECM transmits engine speed through CAN communication).
WIPER SW [Off/Low/High]		Indicates wiper [Off/Low/High] status (BCM transmits front wiper request signal through CAN communication).
YAW RATE [deg/s]		NOTE: The item is displayed, but it is not monitored.
STP LMP DRIVE [On/Off]	×	Indicates [On/Off] status of ICC brake hold relay drive output.
D RANGE SW [On/Off]		Indicates [On/Off] status of "D" or "DS" or "M" positions read from ICC sensor integrated unit through CAN communication; ON when position "D" or "DS" or "M" (TCM transmits shift position signal through CAN communication).
NP RANGE SW [On/Off]		Indicates shift position signal read from ICC sensor integrated unit through CAN communication (TCM transmits shift position signal through CAN communication).
PKB SW [Off]		NOTE: The item is displayed, but it is not monitored.

DIAGNOSIS SYSTEM (ICC SENSOR INTEGRATED UNIT)

< SYSTEM DESCRIPTION >

[ICC]

Monitored item [Unit]	MAIN SIGNAL	Description
PWR SUP MONI [V]	×	Indicates IGN voltage input by ICC sensor integrated unit.
VHCL SPD AT [km/h] or [mph]		Indicates vehicle speed calculated from A/T vehicle speed sensor read from ICC sensor integrated unit through CAN communication (TCM transmits A/T vehicle speed sensor signal through CAN communication).
THRTL OPENING [%]	×	Indicates throttle position read from ICC sensor integrated unit through CAN communication (ECM transmits accelerator pedal position signal through CAN communication).
GEAR [1, 2, 3, 4, 5, 6, 7]		Indicates A/T gear position read from ICC sensor integrated unit through CAN communication (TCM transmits current gear position signal through CAN communication).
CLUTCH SW SIG [On/Off]	×	Indicates [On/Off] status as judged from ICC brake switch signal (ECM transmits ICC brake switch signal through CAN communication). (M/T models)
NP SW SIG [On/Off]	×	Indicates [On/Off] status as judged from park/neutral position switch signal (ECM transmits park/neutral position switch signal through CAN communication). (M/T models)
MODE SIG [OFF, ICC, ASCD]		Indicates the active mode from ICC or ASCD [conventional (fixed speed) cruise control mode].
SET DISP IND [On/Off]		Indicates [On/Off] status of SET switch indicator output.
DISTANCE [m]		Indicates the distance from the vehicle ahead.
RELATIVE SPD [m/s]		Indicates the relative speed of the vehicle ahead.

ACTIVE TEST

CAUTION:

- Never perform “Active Test” while driving the vehicle.
- The “Active Test” cannot be performed when the ICC system warning lamp is illuminated.
- Shift the selector lever to “P” position, and then perform the test. (A/T models)
- Shift the shift knob to neutral position, applied parking brake and then perform the test. (M/T models)

Test item	Description
METER LAMP	The ICC system warning lamp, MAIN switch indicator, and SET switch indicator can be illuminated by ON/OFF operations as necessary.
STOP LAMP	The ICC brake hold relay can be operated by ON/OFF operations as necessary, and the stop lamp can be illuminated.
ICC BUZZER	The ICC warning chime can sound by ON/OFF operations as necessary.

METER LAMP

NOTE:

The test can be performed only when the engine is running.

Test item	Operation	Description	<ul style="list-style-type: none"> • MAIN switch indicator • SET switch indicator • ICC system warning lamp
METER LAMP	Off	Stops transmitting the signals below to end the test. <ul style="list-style-type: none"> • Meter display signal • ICC warning lamp signal 	OFF
	On	Transmits the following signals to the unified meter and A/C amp. via CAN communication. <ul style="list-style-type: none"> • Meter display signal • ICC warning lamp signal 	ON

STOP LAMP

DIAGNOSIS SYSTEM (ICC SENSOR INTEGRATED UNIT)

< SYSTEM DESCRIPTION >

[ICC]

Test item	Operation	Description	Stop lamp
STOP LAMP	Off	Stops transmitting the ICC brake hold relay drive signal below to end the test.	OFF
	On	Transmits the ICC brake hold relay drive signal.	ON

ICC BUZZER

Test item	Operation	Description	ICC warning chime operation sound
ICC BUZZER	Test Start	Transmits the buzzer output signal to the unified meter and A/C amp. via CAN communication.	Beep sound
	Reset	Stops transmitting the buzzer output signal below to end the test.	—
	End	Return to the "SELECT TEST ITEM" screen.	—

DTC/CIRCUIT DIAGNOSIS

C1A00 CONTROL UNIT

Description

INFOID:0000000005622530

ICC sensor integrated unit function description

- It detects the reflected light from the vehicle ahead by irradiating a laser forward. It calculates the vehicle distance from and relative speed with the vehicle ahead depending on the detected signal.
- It calculates the target vehicle distance and the target vehicle speed depending on the signals from various sensors and switches, outputs the engine torque demand to ECM via CAN communication, and outputs the deceleration degree commandment value signal to ABS actuator and electric unit (control unit) via CAN communication.

DTC Logic

INFOID:0000000005622531

DTC DETECTION LOGIC

DTC (On board display)	Trouble diagnosis name	DTC detecting condition	Possible causes
C1A00 (0)	CONTROL UNIT	ICC sensor integrated unit internal malfunction	ICC sensor integrated unit

DTC CONFIRMATION PROCEDURE

1.PERFORM DTC CONFIRMATION PROCEDURE

1. Start the engine.
2. Perform "All DTC Reading" with CONSULT-III.
3. Check if the "C1A00" is detected as the current malfunction in "Self Diagnostic Result" of "ICC".

Is "C1A00" detected as the current malfunction?

- YES >> Refer to [CCS-43. "Diagnosis Procedure"](#).
 NO >> INSPECTION END

Diagnosis Procedure

INFOID:0000000005622532

1.CHECK SELF-DIAGNOSIS RESULTS

Check if any DTC other than "C1A00" is detected in "Self Diagnostic Result" of "ICC".

Is any DTC detected?

- YES >> Perform diagnosis on the detected DTC and repair or replace the malfunctioning parts. Refer to [CCS-116. "DTC Index"](#).
 NO >> Replace the ICC sensor integrated unit. Refer to [CCS-135. "Exploded View"](#).

Special Repair Requirement

INFOID:0000000005622533

DESCRIPTION

Perform the action test after adjusting the laser beam aiming of ICC sensor integrated unit when the following operation is performed.

- Removal and installation of ICC sensor integrated unit
- Replacement of ICC sensor integrated unit

SPECIAL REPAIR REQUIREMENT

1.LASER BEAM AIMING ADJUSTMENT OF ICC SENSOR INTEGRATED UNIT

Adjust the laser beam aiming of the ICC sensor integrated unit. Refer to [CCS-6. "LASER BEAM AIMING ADJUSTMENT : Description"](#).

>> GO TO 2.

A
B
C
D
E
F
G
H
I
J
K
L
M
N
P



2. CHECK ICC SYSTEM

1. Erase the "Self Diagnostic Result", and then perform "All DTC Reading" again after performing the action test. (Refer to [CCS-11, "ACTION TEST : Description"](#) for action test.)
2. Check that the ICC system is normal.

>> WORK END

C1A01 POWER SUPPLY CIRCUIT 1, C1A02 POWER SUPPLY CIRCUIT 2

< DTC/CIRCUIT DIAGNOSIS >

[ICC]

C1A01 POWER SUPPLY CIRCUIT 1, C1A02 POWER SUPPLY CIRCUIT 2

Description

INFOID:0000000005622534

The ICC sensor integrated unit controls the system with the ignition power supply.

DTC Logic

INFOID:0000000005622535

DTC DETECTION LOGIC

DTC (On board display)	Trouble diagnosis name	DTC detecting condition	Possible causes
C1A01 (1)	POWER SUPPLY CIR	ICC sensor integrated unit power supply voltage is excessively low (less than 8 V).	• Connector, harness, fuse • ICC sensor integrated unit
C1A02 (2)	POWER SUPPLY CIR 2	ICC sensor integrated unit power supply voltage is excessively high (more than 19 V).	

DTC CONFIRMATION PROCEDURE

1.PERFORM DTC CONFIRMATION PROCEDURE

1. Start the engine.
2. Turn the MAIN switch of ICC system ON.
3. Perform "All DTC Reading" with CONSULT-III.
4. Check if the "C1A01" or "C1A02" is detected as the current malfunction in "Self Diagnostic Result" of "ICC".

Is "C1A01" or "C1A02" detected as the current malfunction?

- YES >> Refer to [CCS-45, "Diagnosis Procedure"](#).
NO >> Refer to [GI-37, "Intermittent Incident"](#).

Diagnosis Procedure

INFOID:0000000005622536

1.CHECK ICC SENSOR INTEGRATED UNIT POWER SUPPLY AND GROUND CIRCUIT

Check power supply and ground circuit of ICC sensor integrated unit. Refer to [CCS-102, "Diagnosis Procedure"](#).

Is the inspection result normal?

- YES >> Replace the ICC sensor integrated unit. Refer to [CCS-135, "Exploded View"](#).
NO >> Repair or replace the malfunctioning parts.

Special Repair Requirement

INFOID:0000000005622537

DESCRIPTION

Perform the action test after adjusting the laser beam aiming of ICC sensor integrated unit when the following operation is performed.

- Removal and installation of ICC sensor integrated unit
- Replacement of ICC sensor integrated unit

SPECIAL REPAIR REQUIREMENT

1.LASER BEAM AIMING ADJUSTMENT OF ICC SENSOR INTEGRATED UNIT

Adjust the laser beam aiming of the ICC sensor integrated unit. Refer to [CCS-6, "LASER BEAM AIMING ADJUSTMENT : Description"](#).

>> GO TO 2.

2.CHECK ICC SYSTEM

1. Erase the "Self Diagnostic Result", and then perform "All DTC Reading" again after performing the action test. (Refer to [CCS-11, "ACTION TEST : Description"](#) for action test.)

C1A01 POWER SUPPLY CIRCUIT 1, C1A02 POWER SUPPLY CIRCUIT 2

< DTC/CIRCUIT DIAGNOSIS >

[ICC]

2. Check that the ICC system is normal.

>> WORK END

C1A03 VEHICLE SPEED SENSOR

< DTC/CIRCUIT DIAGNOSIS >

[ICC]

C1A03 VEHICLE SPEED SENSOR

Description

INFOID:0000000005622538

The ICC sensor integrated unit receives the vehicle speed signal (wheel speed) from ABS actuator and electric unit (control unit) and the A/T vehicle speed sensor signal (output shaft revolution signal) from TCM via CAN communication.

DTC Logic

INFOID:0000000005622539

DTC DETECTION LOGIC

DTC (On board display)	Trouble diagnosis name	DTC detecting condition	Possible causes
C1A03 (3)	VHCL SPEED SE CIRC	If the vehicle speed signal (wheel speed) from ABS actuator and electric unit (control unit) and the A/T vehicle speed sensor signal (output shaft revolution signal) from TCM, received by the ICC sensor integrated unit via CAN communication, are inconsistent	<ul style="list-style-type: none">• Wheel speed sensor• ABS actuator and electric unit (control unit)• Vehicle speed sensor A/T (output speed sensor)• TCM• ICC sensor integrated unit

NOTE:

If DTC "C1A03" is detected along with DTC "U1000" or "C1A04", first diagnose the DTC "U1000" or "C1A04".

- Refer to [CCS-99, "DTC Logic"](#) for DTC "U1000".
- Refer to [CCS-50, "DTC Logic"](#) for DTC "C1A04".

DTC CONFIRMATION PROCEDURE

1. PERFORM DTC CONFIRMATION PROCEDURE

1. Start the engine.
2. Turn the MAIN switch of ICC system ON.
3. Drive the vehicle at 30 km/h (19 MPH) or more.

CAUTION:

Always drive safely.

4. Stop the vehicle.
5. Perform "All DTC Reading" with CONSULT-III.
6. Check if the "C1A03" is detected as the current malfunction in "Self Diagnostic Result" of "ICC".

Is "C1A03" detected as the current malfunction?

YES >> Refer to [CCS-47, "Diagnosis Procedure \(A/T Models\)"](#) or [CCS-48, "Diagnosis Procedure \(M/T Models\)"](#).

NO >> Refer to [GI-37, "Intermittent Incident"](#).

Diagnosis Procedure (A/T Models)

INFOID:0000000005622540

1. CHECK SELF-DIAGNOSIS RESULTS

Check if "C1A04" or "U1000" is detected other than "C1A03" in "Self Diagnostic Result" of "ICC".

Is any DTC detected?

YES >> Perform diagnosis on the detected DTC and repair or replace the malfunctioning parts. Refer to [CCS-116, "DTC Index"](#).

NO >> GO TO 2.

2. CHECK DATA MONITOR

1. Start the engine.
2. Drive the vehicle.
3. Check that the value of "VHCL SPD AT" is almost the same as the value of "VHCL SPEED SE" in "DATA MONITOR" of "ICC".

CAUTION:

Be careful of the vehicle speed.

C1A03 VEHICLE SPEED SENSOR

[ICC]

< DTC/CIRCUIT DIAGNOSIS >

Is the inspection result normal?

- YES >> Replace the ICC sensor integrated unit. Refer to [CCS-135, "Exploded View"](#).
- NO >> GO TO 3.

3.CHECK TCM SELF-DIAGNOSIS RESULTS

1. Perform "All DTC Reading".
2. Check if any DTC is detected in "Self Diagnostic Result" of "TRANSMISSION".

Is any DTC detected?

- YES >> Perform diagnosis on the detected DTC and repair or replace the malfunctioning parts. Refer to [TM-253, "DTC Index"](#).
- NO >> GO TO 4.

4.CHECK ABS ACTUATOR AND ELECTRIC UNIT (CONTROL UNIT) SELF-DIAGNOSIS RESULTS

Check if any DTC is detected in "Self Diagnostic Result" of "ABS".

Is any DTC detected?

- YES >> Perform diagnosis on the detected DTC and repair or replace the malfunctioning parts. Refer to [BRC-95, "DTC Index"](#).
- NO >> Replace the ICC sensor integrated unit. Refer to [CCS-135, "Exploded View"](#).

Diagnosis Procedure (M/T Models)

INFOID:000000005622541

1.CHECK SELF-DIAGNOSIS RESULTS

Check if "C1A04" or "U1000" is detected other than "C1A03" in "Self Diagnostic Result" of "ICC".

Is any DTC detected?

- YES >> Perform diagnosis on the detected DTC and repair or replace the malfunctioning parts. Refer to [CCS-116, "DTC Index"](#).
- NO >> GO TO 2.

2.CHECK DATA MONITOR

1. Start the engine.
2. Drive the vehicle.
3. Check that the value of "SPEED METER" of "METER/M&A" is almost the same as the value of "VHCL SPEED SE" of "ICC" with "DATA MONITOR".

CAUTION:

Be careful of the vehicle speed.

Is the inspection result normal?

- YES >> Replace the ICC sensor integrated unit. Refer to [CCS-135, "Exploded View"](#).
- NO >> GO TO 3.

3.CHECK UNIFIED METER AND A/C AMP. SELF-DIAGNOSIS RESULTS

1. Perform "All DTC Reading".
2. Check if any DTC is detected in "Self Diagnostic Result" of "METER/M&A".

Is any DTC detected?

- YES >> Perform diagnosis on the detected DTC and repair or replace the malfunctioning parts. Refer to [MWI-102, "DTC Index"](#).
- NO >> GO TO 4.

4.CHECK ABS ACTUATOR AND ELECTRIC UNIT (CONTROL UNIT) SELF-DIAGNOSIS RESULTS

Check if any DTC is detected in "Self Diagnostic Result" of "ABS".

Is any DTC detected?

- YES >> Perform diagnosis on the detected DTC and repair or replace the malfunctioning parts. Refer to [BRC-95, "DTC Index"](#).
- NO >> Replace the ICC sensor integrated unit. Refer to [CCS-135, "Exploded View"](#).

Special Repair Requirement

INFOID:000000005622542

DESCRIPTION

C1A03 VEHICLE SPEED SENSOR

< DTC/CIRCUIT DIAGNOSIS >

[ICC]

Perform the action test after adjusting the laser beam aiming of ICC sensor integrated unit when the following operation is performed.

- Removal and installation of ICC sensor integrated unit
- Replacement of ICC sensor integrated unit

SPECIAL REPAIR REQUIREMENT

1.LASER BEAM AIMING ADJUSTMENT OF ICC SENSOR INTEGRATED UNIT

Adjust the laser beam aiming of the ICC sensor integrated unit. Refer to [CCS-6, "LASER BEAM AIMING ADJUSTMENT : Description"](#).

>> GO TO 2.

2.CHECK ICC SYSTEM

1. Erase the "Self Diagnostic Result", and then perform "All DTC Reading" again after performing the action test. (Refer to [CCS-11, "ACTION TEST : Description"](#) for action test.)
2. Check that the ICC system is normal.

>> WORK END

A
B
C
D
E
F
G
H
I
J
K
L
M
N
P

CCS

C1A04 ABS/TCS/VDC SYSTEM

Description

INFOID:000000005622543

- ABS actuator and electric unit (control unit) transmits the vehicle speed signal (wheel speed), the stop lamp switch signal and VDC/TCS/ABS system operation condition to ICC sensor integrated unit via CAN communication.
- ABS actuator and electric unit (control unit) receives the deceleration degree command value signal from the ICC sensor integrated unit with CAN communication and controls the brake fluid pressure.

DTC Logic

INFOID:000000005622544

DTC DETECTION LOGIC

DTC (On board display)	Trouble diagnosis name	DTC detecting condition	Possible causes
C1A04 (4)	ABS/TCS/VDC CIRC	If a malfunction occurs in the VDC/TCS/ABS system	ABS actuator and electric unit (control unit)

NOTE:

If DTC "C1A04" is detected along with DTC "U1000", first diagnose the DTC "U1000". Refer to [CCS-99, "DTC Logic"](#).

Diagnosis Procedure

INFOID:000000005622545

1. CHECK SELF-DIAGNOSIS RESULTS

1. Perform "All DTC Reading" with CONSULT-III.
2. Check if the "U1000" is detected other than "C1A04" in "Self Diagnostic Result" of "ICC".

Is "U1000" detected?

YES >> Perform the CAN communication system inspection. Repair or replace the malfunctioning parts. Refer to [CCS-99, "DTC Logic"](#).

NO >> GO TO 2.

2. CHECK ABS ACTUATOR AND ELECTRIC UNIT (CONTROL UNIT) SELF-DIAGNOSIS RESULTS

Check if any DTC is detected in "Self Diagnostic Result" of "ABS".

Is any DTC detected?

YES >> Perform diagnosis on the detected DTC and repair or replace the malfunctioning parts. Refer to [BRC-95, "DTC Index"](#).

NO >> Replace the ICC sensor integrated unit. Refer to [CCS-135, "Exploded View"](#).

Special Repair Requirement

INFOID:000000005622546

DESCRIPTION

Perform the action test after adjusting the laser beam aiming of ICC sensor integrated unit when the following operation is performed.

- Removal and installation of ICC sensor integrated unit
- Replacement of ICC sensor integrated unit

SPECIAL REPAIR REQUIREMENT

1. LASER BEAM AIMING ADJUSTMENT OF ICC SENSOR INTEGRATED UNIT

Adjust the laser beam aiming of the ICC sensor integrated unit. Refer to [CCS-6, "LASER BEAM AIMING ADJUSTMENT : Description"](#).

>> GO TO 2.

2. CHECK ICC SYSTEM

C1A04 ABS/TCS/VDC SYSTEM

< DTC/CIRCUIT DIAGNOSIS >

[ICC]

1. Erase the "Self Diagnostic Result", and then perform "All DTC Reading" again after performing the action test. (Refer to [CCS-11, "ACTION TEST : Description"](#) for action test.)
2. Check that the ICC system is normal.

A

>> WORK END

B

C

D

E

F

G

H

I

J

K

L

M

N

CCS

P

C1A05 BRAKE SW/STOP LAMP SW

< DTC/CIRCUIT DIAGNOSIS >

[ICC]

C1A05 BRAKE SW/STOP LAMP SW

Description

INFOID:00000000562547

- ICC brake switch is turned OFF and stop lamp switch is turned ON when depressing the brake pedal.
- ICC clutch switch is turned OFF when depressing the clutch pedal (M/T models).

NOTE:

- ICC clutch switch and ICC brake switch are connected in series.
- ICC brake switch signal is input to ECM. The signal is transmitted from ECM to ICC sensor integrated unit via CAN communication.
- Stop lamp switch signal is input to ECM and ABS actuator and electric unit (control unit). These signals are transmitted from ECM and ABS actuator and electric unit (control unit) to ICC sensor integrated unit via CAN communication.

DTC Logic

INFOID:00000000562548

DTC DETECTION LOGIC

DTC (On board display)	Trouble diagnosis name	DTC detecting condition	Possible causes
C1A05 (5)	BRAKE SW/STOP L SW	If ICC sensor integrated unit receives signals indicating that the stop lamp switch [from ABS actuator and electric unit (control unit)] is ON and the ICC brake switch (from ECM) is ON	<ul style="list-style-type: none"> • Stop lamp switch circuit • ICC brake switch circuit • ICC clutch switch circuit (M/T models) • Stop lamp switch • ICC brake switch • ICC clutch switch (M/T models) • Incorrect stop lamp switch installation • Incorrect ICC brake switch installation • Incorrect ICC clutch switch installation (M/T models) • ECM • ABS actuator and electric unit (control unit)

NOTE:

If DTC "C1A05" is detected along with DTC "U1000", "U0401", "U0415", or "U0121", first diagnose the DTC "U1000", "U0401", "U0415", or "U0121".

- DTC "U1000": Refer to [CCS-99, "Diagnosis Procedure"](#).
- DTC "U0401": Refer to [CCS-93, "Diagnosis Procedure"](#).
- DTC "U0415": Refer to [CCS-97, "Diagnosis Procedure"](#).
- DTC "U0121": Refer to [CCS-91, "Diagnosis Procedure"](#).

Diagnosis Procedure (A/T Models)

INFOID:00000000562549

1. CHECK SELF-DIAGNOSIS RESULTS

1. Perform "All DTC Reading" with CONSULT-III.
2. Check if "U1000", "U0401", "U0415", or "U0121" is detected other than "C1A05" in "Self Diagnostic Result" of "ICC".

Is any DTC detected?

- YES >> Perform diagnosis on the detected DTC and repair or replace the malfunctioning parts. Refer to [CCS-116, "DTC Index"](#).
- NO >> GO TO 2.

2. CHECK ICC BRAKE SWITCH WITH ICC DATA MONITOR

Check that "BRAKE SW" operate normally in "DATA MONITOR" of "ICC".

Is the inspection result normal?

- YES >> GO TO 3.

C1A05 BRAKE SW/STOP LAMP SW

[ICC]

< DTC/CIRCUIT DIAGNOSIS >

NO >> GO TO 4.

3.CHECK STOP LAMP SWITCH WITH ABS DATA MONITOR

Check that "STOP LAMP SW" operate normally in "DATA MONITOR" of "ABS".

Is the inspection result normal?

YES >> GO TO 13.

NO >> GO TO 9.

4.CHECK ICC BRAKE SWITCH INSTALLATION

1. Turn ignition switch OFF.
2. Check ICC brake switch for correct installation. Refer to [BR-8. "Inspection and Adjustment"](#).

Is the inspection result normal?

YES >> GO TO 5.

NO >> Adjust ICC brake switch installation. Refer to [BR-8. "Inspection and Adjustment"](#).

5.CHECK ICC BRAKE SWITCH

1. Disconnect ICC brake switch connector.
2. Check ICC brake switch. Refer to [CCS-58. "Component Inspection \(ICC Brake Switch\)"](#).

Is the inspection result normal?

YES >> GO TO 6.

NO >> Replace ICC brake switch.

6.CHECK ICC BRAKE SWITCH POWER SUPPLY CIRCUIT

1. Turn ignition switch ON.
2. Check voltage between ICC brake switch harness connector and ground.

Terminal		Voltage (Approx.)
(+)	(-)	
ICC brake switch		Ground
Connector	Terminal	
E114	1	
		Battery voltage

Is the inspection result normal?

YES >> GO TO 7.

NO >> Repair or replace ICC brake switch power supply circuit.

7.CHECK HARNESS BETWEEN ICC BRAKE SWITCH AND ECM

1. Turn ignition switch OFF.
2. Disconnect ECM connector.
3. Check for continuity between ICC brake switch harness connector and ECM harness connector.

ICC brake switch		ECM		Continuity
Connector	Terminal	Connector	Terminal	
E114	2	M107	126	Existed

Is the inspection result normal?

YES >> GO TO 8.

NO >> Repair the harness or connectors.

8.PERFORM SELF-DIAGNOSIS OF ECM

1. Connect all connectors again if the connectors are disconnected.
2. Turn ignition switch ON.
3. Perform "All DTC Reading".
4. Check if any DTC is detected in "Self Diagnostic Result" of "ENGINE". Refer to [EC-548. "DTC Index"](#).

Is any DTC detected?

YES >> Repair or replace the malfunctioning parts identified by the self-diagnosis result.

NO >> Replace ICC sensor integrated unit. Refer to [CCS-135. "Exploded View"](#).

A
B
C
D
E
F
G
H
I
J
K
L
M
N
P

CCS

C1A05 BRAKE SW/STOP LAMP SW

< DTC/CIRCUIT DIAGNOSIS >

[ICC]

9. CHECK STOP LAMP SWITCH INSTALLATION

1. Turn ignition switch OFF.
2. Check stop lamp switch for correct installation. Refer to [BR-8, "Inspection and Adjustment"](#).

Is the inspection result normal?

YES >> GO TO 10.

NO >> Adjust stop lamp switch installation. Refer to [BR-8, "Inspection and Adjustment"](#).

10. CHECK STOP LAMP SWITCH

1. Disconnect stop lamp switch connector.
2. Check stop lamp switch. Refer to [CCS-58, "Component Inspection \(Stop Lamp Switch\)"](#).

Is the inspection result normal?

YES >> GO TO 11.

NO >> Replace stop lamp switch.

11. CHECK STOP LAMP SWITCH POWER SUPPLY CIRCUIT

1. Turn ignition switch ON.
2. Check voltage between stop lamp switch harness connector and ground.

Terminal		Voltage (Approx.)
(+)	(-)	
Stop lamp switch		Ground
Connector	Terminal	
E110	1	
		Battery voltage

Is the inspection result normal?

YES >> GO TO 12.

NO >> Repair or replace stop lamp switch power supply circuit.

12. CHECK HARNESS BETWEEN STOP LAMP SWITCH AND ABS ACTUATOR AND ELECTRIC UNIT (CONTROL UNIT)

1. Turn ignition switch OFF.
2. Disconnect ABS actuator and electric unit (control unit) connector.
3. Check continuity between stop lamp switch harness connector and ABS actuator and electric unit (control unit) harness connector.

Stop lamp switch		ABS actuator and electric unit (control unit)		Continuity
Connector	Terminal	Connector	Terminal	
E110	2	E41	30	Existed

Is the inspection result normal?

YES >> GO TO 14.

NO >> Repair the harness or connectors.

13. PERFORM SELF-DIAGNOSIS OF ECM

1. Connect all connectors again if the connectors are disconnected.
2. Turn ignition switch ON.
3. Perform "All DTC Reading".
4. Check if any DTC is detected in "Self Diagnostic Result" of "ENGINE". Refer to [EC-548, "DTC Index"](#).

Is any DTC detected?

YES >> Repair or replace the malfunctioning parts identified by the self-diagnosis result.

NO >> GO TO 14.

14. PERFORM SELF-DIAGNOSIS OF ABS ACTUATOR AND ELECTRIC UNIT (CONTROL UNIT)

1. Connect all connectors again if the connectors are disconnected.
2. Turn ignition switch ON.

C1A05 BRAKE SW/STOP LAMP SW

[ICC]

< DTC/CIRCUIT DIAGNOSIS >

3. Perform "All DTC Reading".
4. Check if any DTC is detected in "Self Diagnostic Result" of "ABS". Refer to [BRC-95, "DTC Index"](#).

Is any DTC detected?

- YES >> Repair or replace the malfunctioning parts identified by the self-diagnosis result.
 NO >> Replace ICC sensor integrated unit. Refer to [CCS-135, "Exploded View"](#).

Diagnosis Procedure (M/T Models)

INFOID:000000005622550

1.CHECK SELF-DIAGNOSIS RESULTS

1. Perform "All DTC Reading" with CONSULT-III.
2. Check if "U1000", "U0401", "U0415", or "U0121" is detected other than "C1A05" in "Self Diagnostic Result" of "ICC".

Is any DTC detected?

- YES >> Perform diagnosis on the detected DTC and repair or replace the malfunctioning parts. Refer to [CCS-116, "DTC Index"](#).
 NO >> GO TO 2.

2.CHECK ICC BRAKE SWITCH WITH ICC DATA MONITOR

Check that "BRAKE SW" operate normally in "DATA MONITOR" of "ICC".

Is the inspection result normal?

- YES >> GO TO 3.
 NO >> GO TO 4.

3.CHECK STOP LAMP SWITCH WITH ABS DATA MONITOR

Check that "STOP LAMP SW" operate normally in "DATA MONITOR" of "ABS".

Is the inspection result normal?

- YES >> GO TO 16.
 NO >> GO TO 12.

4.CHECK ICC CLUTCH SWITCH INSTALLATION

1. Turn ignition switch OFF.
2. Check ICC clutch switch for correct installation. Refer to [CL-6, "Inspection and Adjustment"](#).

Is the inspection result normal?

- YES >> GO TO 5.
 NO >> Adjust ICC clutch switch installation. Refer to [CL-6, "Inspection and Adjustment"](#).

5.CHECK ICC CLUTCH SWITCH

1. Disconnect ICC clutch switch connector.
2. Check ICC clutch switch. Refer to [CCS-58, "Component Inspection \(ICC Clutch Switch\)"](#).

Is the inspection result normal?

- YES >> GO TO 6.
 NO >> Replace ICC clutch switch.

6.CHECK ICC CLUTCH SWITCH POWER SUPPLY CIRCUIT

1. Turn ignition switch ON.
2. Check voltage between ICC clutch switch harness connector and ground.

Terminal		Voltage (Approx.)
(+)	(-)	
ICC clutch switch		Ground
Connector	Terminal	
E113	1	
		Battery voltage

Is the inspection result normal?

- YES >> GO TO 7.
 NO >> Repair or replace ICC clutch switch power supply circuit.

CCS

C1A05 BRAKE SW/STOP LAMP SW

< DTC/CIRCUIT DIAGNOSIS >

[ICC]

7. CHECK ICC BRAKE SWITCH INSTALLATION

1. Turn ignition switch OFF.
2. Check ICC brake switch for correct installation. Refer to [BR-8, "Inspection and Adjustment"](#).

Is the inspection result normal?

YES >> GO TO 8.

NO >> Adjust ICC brake switch installation. Refer to [BR-8, "Inspection and Adjustment"](#).

8. CHECK ICC BRAKE SWITCH

1. Turn ignition switch OFF.
2. Disconnect ICC brake switch connector.
3. Check ICC brake switch. Refer to [CCS-58, "Component Inspection \(ICC Brake Switch\)"](#).

Is the inspection result normal?

YES >> GO TO 9.

NO >> Replace ICC brake switch.

9. CHECK HARNESS BETWEEN ICC CLUTCH SWITCH AND ICC BRAKE SWITCH

1. Check continuity between ICC clutch switch harness connector and ICC brake switch harness connector.

ICC clutch switch		ICC brake switch		Continuity
Connector	Terminal	Connector	Terminal	
E113	2	E114	1	Existed

2. Check continuity between ICC clutch switch harness connector and ground.

ICC clutch switch		Ground	Continuity
Connector	Terminal		
E113	2		Not existed

Is the inspection result normal?

YES >> GO TO 10.

NO >> Repair the harness or connectors.

10. CHECK HARNESS BETWEEN ICC BRAKE SWITCH AND ECM

1. Turn ignition switch OFF.
2. Disconnect ECM connector.
3. Check for continuity between ICC brake switch harness connector and ECM harness connector.

ICC brake switch		ECM		Continuity
Connector	Terminal	Connector	Terminal	
E114	2	M107	126	Existed

Is the inspection result normal?

YES >> GO TO 11.

NO >> Repair the harness or connectors.

11. PERFORM SELF-DIAGNOSIS OF ECM

1. Connect all connectors again if the connectors are disconnected.
2. Turn ignition switch ON.
3. Perform "All DTC Reading".
4. Check if any DTC is detected in "Self Diagnostic Result" of "ENGINE". Refer to [EC-548, "DTC Index"](#).

Is any DTC detected?

YES >> Repair or replace the malfunctioning parts identified by the self-diagnosis result.

NO >> Replace ICC sensor integrated unit. Refer to [CCS-135, "Exploded View"](#).

12. CHECK STOP LAMP SWITCH INSTALLATION

1. Turn ignition switch OFF.

C1A05 BRAKE SW/STOP LAMP SW

[ICC]

< DTC/CIRCUIT DIAGNOSIS >

2. Check stop lamp switch for correct installation. Refer to [BR-8. "Inspection and Adjustment"](#).

Is the inspection result normal?

YES >> GO TO 13.

NO >> Adjust stop lamp switch installation. Refer to [BR-8. "Inspection and Adjustment"](#).

13.CHECK STOP LAMP SWITCH

1. Disconnect stop lamp switch connector.
2. Check stop lamp switch. Refer to [CCS-58. "Component Inspection \(Stop Lamp Switch\)"](#).

Is the inspection result normal?

YES >> GO TO 14.

NO >> Replace stop lamp switch.

14.CHECK STOP LAMP SWITCH POWER SUPPLY CIRCUIT

1. Turn ignition switch ON.
2. Check voltage between stop lamp switch harness connector and ground.

Terminal		Voltage (Approx.)
(+)	(-)	
Stop lamp switch		Ground
Connector	Terminal	
E110	1	
		Battery voltage

Is the inspection result normal?

YES >> GO TO 15.

NO >> Repair or replace stop lamp switch power supply circuit.

15.CHECK HARNESS BETWEEN STOP LAMP SWITCH AND ABS ACTUATOR AND ELECTRIC UNIT (CONTROL UNIT)

1. Turn ignition switch OFF.
2. Disconnect ABS actuator and electric unit (control unit) connector.
3. Check continuity between stop lamp switch harness connector and ABS actuator and electric unit (control unit) harness connector.

Stop lamp switch		ABS actuator and electric unit (control unit)		Continuity
Connector	Terminal	Connector	Terminal	
E110	2	E41	30	Existed

Is the inspection result normal?

YES >> GO TO 16.

NO >> Repair the harness or connectors.

16.PERFORM SELF-DIAGNOSIS OF ECM

1. Connect all connectors again if the connectors are disconnected.
2. Turn ignition switch ON.
3. Perform "All DTC Reading".
4. Check if any DTC is detected in "Self Diagnostic Result" of "ENGINE". Refer to [EC-548. "DTC Index"](#).

Is any DTC detected?

YES >> Repair or replace the malfunctioning parts identified by the self-diagnosis result.

NO >> GO TO 17.

17.PERFORM SELF-DIAGNOSIS OF ABS ACTUATOR AND ELECTRIC UNIT (CONTROL UNIT)

1. Connect all connectors again if the connectors are disconnected.
2. Turn ignition switch ON.
3. Perform "All DTC Reading".
4. Check if any DTC is detected in "Self Diagnostic Result" of "ABS". Refer to [BRC-95. "DTC Index"](#).

Is any DTC detected?

A
B
C
D
E
F
G
H
I
J
K
L
M
N

CCS

P

C1A05 BRAKE SW/STOP LAMP SW

[ICC]

< DTC/CIRCUIT DIAGNOSIS >

- YES >> Repair or replace the malfunctioning parts identified by the self-diagnosis result.
NO >> Replace ICC sensor integrated unit. Refer to [CCS-135, "Exploded View"](#).

Component Inspection (ICC Brake Switch)

INFOID:000000005622551

1.CHECK ICC BRAKE SWITCH

Check for continuity between ICC brake switch terminals.

Terminal	Condition	Continuity	
1	2	When brake pedal is depressed	Not existed
		When brake pedal is not depressed	Existed

Is the inspection result normal?

- YES >> INSPECTION END
NO >> Replace ICC brake switch.

Component Inspection (ICC Clutch Switch)

INFOID:000000005622552

1.CHECK ICC CLUTCH SWITCH

Check for continuity between ICC clutch switch terminals.

Terminal	Condition	Continuity	
1	2	When clutch pedal is depressed	Not existed
		When clutch pedal is not depressed	Existed

Is the inspection result normal?

- YES >> INSPECTION END
NO >> Replace ICC clutch switch.

Component Inspection (Stop Lamp Switch)

INFOID:000000005622553

1.CHECK STOP LAMP SWITCH

Check for continuity between stop lamp switch terminals.

Terminal	Condition	Continuity	
1	2	When brake pedal is depressed	Existed
		When brake pedal is not depressed	Not existed
3	4	When brake pedal is depressed	Existed
		When brake pedal is not depressed	Not existed

Is the inspection result normal?

- YES >> INSPECTION END
NO >> Replace stop lamp switch.

Special Repair Requirement

INFOID:000000005622554

DESCRIPTION

Perform the action test after adjusting the laser beam aiming of ICC sensor integrated unit when the following operation is performed.

- Removal and installation of ICC sensor integrated unit
- Replacement of ICC sensor integrated unit

SPECIAL REPAIR REQUIREMENT

C1A05 BRAKE SW/STOP LAMP SW

< DTC/CIRCUIT DIAGNOSIS >

[ICC]

1. LASER BEAM AIMING ADJUSTMENT OF ICC SENSOR INTEGRATED UNIT

Adjust the laser beam aiming of the ICC sensor integrated unit. Refer to [CCS-6. "LASER BEAM AIMING ADJUSTMENT : Description"](#).

>> GO TO 2.

2. CHECK ICC SYSTEM

1. Erase the "Self Diagnostic Result", and then perform "All DTC Reading" again after performing the action test. (Refer to [CCS-11. "ACTION TEST : Description"](#) for action test.)
2. Check that the ICC system is normal.

>> WORK END

A
B
C
D
E
F
G
H
I
J
K
L
M
N
P

CCS

C1A06 OPERATION SW

Description

INFOID:000000005622555

- Operate the ICC system ON/OFF and vehicle speed/vehicle distance setting by the ICC steering switch.
- The ICC steering switch signal is input to the ECM. It is transmitted from ECM to ICC sensor integrated unit via CAN communication.

DTC Logic

INFOID:000000005622556

DTC DETECTION LOGIC

DTC (On board display)	Trouble diagnosis name	DTC detecting condition	Possible causes
C1A06 (6)	OPERATION SW CIRC	If the input signal from ICC steering switch is malfunctioning	<ul style="list-style-type: none"> • ICC steering switch circuit • ICC steering switch • ECM

NOTE:

If DTC "C1A06" is detected along with DTC "U1000", first diagnose the DTC "U1000". Refer to [CCS-99, "DTC Logic"](#).

DTC CONFIRMATION PROCEDURE

1. PERFORM DTC CONFIRMATION PROCEDURE

1. Start the engine.
2. Wait for approximately 5 minutes after turning the MAIN switch of ICC system ON.
3. Perform "All DTC Reading" with CONSULT-III.
4. Check if the "C1A06" is detected as the current malfunction in "Self Diagnostic Result" of "ICC".

Is "C1A06" detected as the current malfunction?

- YES >> Refer to [CCS-60, "Diagnosis Procedure"](#).
 NO >> Refer to [GI-37, "Intermittent Incident"](#).

Diagnosis Procedure

INFOID:000000005622557

1. CHECK SELF-DIAGNOSIS RESULTS

Check if "U1000" is detected other than "C1A06" in "Self Diagnostic Result" of "ICC".

Is "U1000" detected?

- YES >> Perform the CAN communication system inspection. Repair or replace the malfunctioning parts.
 Refer to [CCS-99, "DTC Logic"](#).
 NO >> GO TO 2.

2. CHECK ICC STEERING SWITCH

1. Turn the ignition switch OFF.
2. Disconnect the ICC steering switch connector.
3. Check the ICC steering switch. Refer to [CCS-61, "Component Inspection"](#).

Is the inspection result normal?

- YES >> GO TO 3.
 NO >> Replace the ICC steering switch.

3. CHECK HARNESS BETWEEN SPIRAL CABLE AND ECM

1. Disconnect the ECM connector.
2. Check for continuity between the spiral cable harness connector and ECM harness connector.

Spiral cable		ECM		Continuity
Connector	Terminal	Connector	Terminal	
M36	25	M107	101	Existed
	32		108	

3. Check for continuity between spiral cable harness connector and ground.

Spiral cable		Ground	Continuity
Connector	Terminal		
M36	25		Not existed
	32		

Is the inspection result normal?

- YES >> GO TO 4.
- NO >> Repair the harnesses or connectors.

4.CHECK SPIRAL CABLE

Check for continuity between spiral cable terminals.

Spiral cable		Continuity
Terminal		
13	25	Existed
16	32	

Is the inspection result normal?

- YES >> GO TO 5.
- NO >> Replace the spiral cable.

5.PERFORM SELF-DIAGNOSIS OF ECM

1. Connect the connectors of ICC steering switch and ECM connector.
2. Turn the ignition switch ON.
3. Perform "All DTC Reading".
4. Check if any DTC is detected in "Self Diagnostic Result" of "ENGINE".

Is any DTC detected?

- YES >> Perform self-diagnosis on the detected DTC and repair or replace the malfunctioning parts. Refer to [EC-548. "DTC Index"](#).
- NO >> Replace the ICC sensor integrated unit. Refer to [CCS-135. "Exploded View"](#).

Component Inspection

INFOID:000000005622558

1.CHECK ICC STEERING SWITCH

Check resistance between ICC steering switch terminals.

Terminal	Switch operation	Resistance [Ω]
13 16	When pressing MAIN switch	Approx. 0
	When pressing CANCEL switch	Approx. 309
	When pressing DISTANCE switch	Approx. 741
	When pressing SET/COAST switch	Approx. 1406
	When pressing RESUME/ACCELERATE switch	Approx. 2586
	When all switches are not pressed	Approx. 5456

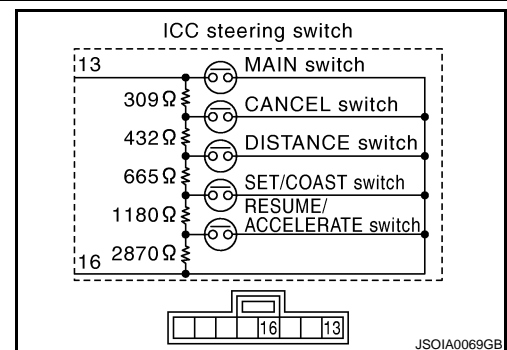

A
B
C
D
E
F
G
H
I
J
K
L
M
N
P



< DTC/CIRCUIT DIAGNOSIS >

Is the inspection result normal?

- YES >> INSPECTION END
- NO >> Replace the ICC steering switch.

Special Repair Requirement

INFOID:000000005622559

DESCRIPTION

Perform the action test after adjusting the laser beam aiming of ICC sensor integrated unit when the following operation is performed.

- Removal and installation of ICC sensor integrated unit
- Replacement of ICC sensor integrated unit

SPECIAL REPAIR REQUIREMENT

1.LASER BEAM AIMING ADJUSTMENT OF ICC SENSOR INTEGRATED UNIT

Adjust the laser beam aiming of the ICC sensor integrated unit. Refer to [CCS-6. "LASER BEAM AIMING ADJUSTMENT : Description"](#).

>> GO TO 2.

2.CHECK ICC SYSTEM

1. Erase the "Self Diagnostic Result", and then perform "All DTC Reading" again after performing the action test. (Refer to [CCS-11. "ACTION TEST : Description"](#) for action test.)
2. Check that the ICC system is normal.

>> WORK END

C1A12 LASER BEAM OFF CENTER

< DTC/CIRCUIT DIAGNOSIS >

[ICC]

C1A12 LASER BEAM OFF CENTER

Description

INFOID:000000005622560

ICC sensor integrated unit detects the reflected light from the vehicle ahead by irradiating a laser forward. It calculates the distance from and relative speed with the vehicle ahead based on the detected signal.

DTC Logic

INFOID:000000005622561

DTC DETECTION LOGIC

DTC (On board display)	Trouble diagnosis name	DTC detecting condition	Possible causes
C1A12 (12)	LASER BEAM OFFCNTR	Laser beam of ICC sensor integrated unit is off the aiming point	Laser beam is off the aiming point

Diagnosis Procedure

INFOID:000000005622562

1. ADJUST LASER BEAM AIMING

1. Adjust the laser beam aiming with CONSULT-III. Refer to [CCS-6, "LASER BEAM AIMING ADJUSTMENT : Description"](#).
2. Perform "All DTC Reading".
3. Check if the "C1A12" is detected in "Self Diagnostic Result" of "ICC".

Is "C1A12" detected?

- YES >> Replace ICC sensor integrated unit. Refer to [CCS-135, "Exploded View"](#).
NO >> INSPECTION END

Special Repair Requirement

INFOID:000000005622563

DESCRIPTION

Perform the action test after adjusting the laser beam aiming of ICC sensor integrated unit when the following operation is performed.

- Removal and installation of ICC sensor integrated unit
- Replacement of ICC sensor integrated unit

SPECIAL REPAIR REQUIREMENT

1. LASER BEAM AIMING ADJUSTMENT OF ICC SENSOR INTEGRATED UNIT

Adjust the laser beam aiming of the ICC sensor integrated unit. Refer to [CCS-6, "LASER BEAM AIMING ADJUSTMENT : Description"](#).

>> GO TO 2.

2. CHECK ICC SYSTEM

1. Erase the "Self Diagnostic Result", and then perform "All DTC Reading" again after performing the action test. (Refer to [CCS-11, "ACTION TEST : Description"](#) for action test.)
2. Check that the ICC system is normal.

>> WORK END

A
B
C
D
E
F
G
H
I
J
K
L
M
N
P

CCS

C1A13 STOP LAMP RELAY

< DTC/CIRCUIT DIAGNOSIS >

[ICC]

C1A13 STOP LAMP RELAY

Description

INFOID:000000005622564

The ICC brake hold relay activates the stop lamp by the ICC brake hold relay drive signal (stop lamp drive signal) outputted by the ICC sensor integrated unit.

DTC Logic

INFOID:000000005622565

DTC DETECTION LOGIC

DTC (On board display)	Trouble diagnosis name	DTC detecting condition	Possible causes
C1A13 (13)	STOP LAMP RLY FIX	<ul style="list-style-type: none">If the stop lamp is not activated even though the ICC sensor integrated unit is transmitting a ICC brake hold relay drive signalIf the stop lamp is activated even though the ICC sensor integrated unit is not transmitting a ICC brake hold relay drive signal	<ul style="list-style-type: none">Stop lamp switch circuitICC brake switch circuitICC brake hold relay circuitStop lamp switchICC brake switchICC brake hold relayIncorrect stop lamp switch installationIncorrect ICC brake switch installationECMABS actuator and electric unit (control unit)

NOTE:

If DTC "C1A13" is detected along with DTC "U1000", first diagnose the DTC "U1000". Refer to [CCS-99, "DTC Logic"](#).

DTC CONFIRMATION PROCEDURE

1. PERFORM DTC CONFIRMATION PROCEDURE (1)

1. Start the engine.
2. Perform the active test item "STOP LAMP" with CONSULT-III.
3. Perform "All DTC Reading".
4. Check if the "C1A13" is detected as the current malfunction in the "Self Diagnostic Result" of "ICC".

Is "C1A13" detected as the current malfunction?

YES >> Refer to [CCS-64, "Diagnosis Procedure"](#).

NO >> GO TO 2.

2. PERFORM DTC CONFIRMATION PROCEDURE (2)

1. Drive at the vehicle speed of 40 km/h (25 MPH) or more for approximately 20 seconds or more without the brake pedal depressed.

CAUTION:

Always drive safely.

NOTE:

If it is outside the above condition, repeat step 1.

2. Perform "All DTC Reading".
3. Check if the "C1A13" is detected as the current malfunction in the "Self Diagnostic Result" of "ICC".

Is "C1A13" detected as the current malfunction?

YES >> Refer to [CCS-64, "Diagnosis Procedure"](#).

NO >> Refer to [GI-37, "Intermittent Incident"](#).

Diagnosis Procedure

INFOID:000000005622566

1. CHECK SELF-DIAGNOSIS RESULTS

Check if "U1000" is detected other than "C1A13" in "Self Diagnostic Result" of "ICC".

Is "U1000" detected?

C1A13 STOP LAMP RELAY

[ICC]

< DTC/CIRCUIT DIAGNOSIS >

- YES >> Perform the CAN communication system inspection. Repair or replace the malfunctioning parts.
Refer to [CCS-99, "DTC Logic"](#).
- NO >> GO TO 2.

2.CHECK STOP LAMP SWITCH WITH ICC DATA MONITOR

Check that "STOP LAMP SW" operate normally in "DATA MONITOR" of "ICC".

Is the inspection result normal?

- YES >> GO TO 10.
NO >> GO TO 3.

3.CHECK STOP LAMP SWITCH INSTALLATION

1. Turn ignition switch OFF.
2. Check stop lamp switch for correct installation. Refer to [BR-8, "Inspection and Adjustment"](#).

Is the inspection result normal?

- YES >> GO TO 4.
NO >> Adjust stop lamp switch installation. Refer to [BR-8, "Inspection and Adjustment"](#).

4.CHECK STOP LAMP SWITCH

1. Disconnect stop lamp switch connector.
2. Check stop lamp switch. Refer to [CCS-58, "Component Inspection \(Stop Lamp Switch\)"](#).

Is the inspection result normal?

- YES >> GO TO 5.
NO >> Replace stop lamp switch.

5.CHECK STOP LAMP ILLUMINATION

1. Connect stop lamp switch connector.
2. Remove ICC brake hold relay.
3. Check that the stop lamp is illuminated by depressing the brake pedal to turn the stop lamp ON.

Is the inspection result normal?

- YES >> GO TO 6.
NO >> Repair the harnesses or connectors.

6.CHECK HARNESS BETWEEN STOP LAMP SWITCH AND ECM

1. Turn ignition switch OFF.
2. Disconnect stop lamp switch connector and ECM connector.
3. Check for continuity between the stop lamp switch harness connector and ECM harness connector.

Stop lamp switch		ECM		Continuity
Connector	Terminal	Connector	Terminal	
E110	4	M107	122	Existed

Is the inspection result normal?

- YES >> GO TO 7.
NO >> Repair the harnesses or connectors.

7.CHECK ICC BRAKE HOLD RELAY CIRCUIT

1. Connect ICC brake hold relay and ECM connector.
2. Check that the stop lamp does not illuminate when brake pedal is not depressed.

Is the inspection result normal?

- YES >> GO TO 9.
NO >> GO TO 8.

8.CHECK ICC BRAKE HOLD RELAY

1. Remove ICC brake hold relay.
2. Check ICC brake hold relay. Refer to [CCS-69, "Component Inspection"](#).

Is the inspection result normal?

- YES >> GO TO 9.

C1A13 STOP LAMP RELAY

[ICC]

< DTC/CIRCUIT DIAGNOSIS >

NO >> Replace ICC brake hold relay.

9. PERFORM SELF-DIAGNOSIS OF ECM

1. Connect all connectors again if the connectors are disconnected.
2. Turn ignition switch ON.
3. Perform "All DTC Reading".
4. Check if any DTC is detected in "Self Diagnostic Result" of "ENGINE". Refer to [EC-548, "DTC Index"](#).

Is any DTC detected?

YES >> Repair or replace the malfunctioning parts identified by the self-diagnosis result.

NO >> Replace ICC sensor integrated unit. Refer to [CCS-135, "Exploded View"](#).

10. CHECK HARNESS BETWEEN ICC SENSOR INTEGRATED UNIT AND ICC BRAKE HOLD RELAY

1. Turn ignition switch OFF.
2. Disconnect ICC sensor integrated unit connector and remove ICC brake hold relay.
3. Check for continuity between ICC sensor integrated unit harness connector and ICC brake hold relay harness connector.

ICC sensor integrated unit		ICC brake hold relay		Continuity
Connector	Terminal	Connector	Terminal	
E67	2	E51	2	Existed

4. Check for continuity between ICC sensor integrated unit harness connector and ground.

ICC sensor integrated unit		Ground	Continuity
Connector	Terminal		
E67	2		Not existed

Is the inspection result normal?

YES >> GO TO 11.

NO >> Repair the harnesses or connectors.

11. CHECK ICC BRAKE HOLD RELAY GROUND CIRCUIT

Check for continuity between ICC brake hold relay harness connector and ground.

ICC brake hold relay		Ground	Continuity
Connector	Terminal		
E51	1		Existed

Is the inspection result normal?

YES >> GO TO 12.

NO >> Repair the harnesses or connectors.

12. CHECK ICC SENSOR INTEGRATED UNIT STANDARD VOLTAGE

1. Connect ICC sensor integrated unit connector.
2. Turn ignition switch ON.
3. Perform "STOP LAMP" on "Active Test" of "ICC", and then check the voltage between ICC brake hold relay harness connector and ground.

Terminal		Condition	Voltage (Approx.)
(+)	(-)		
ICC brake hold relay		Active Test item "STOP LAMP"	0 V
Connector	Terminal		
E51	2	Off	Battery voltage
		On	

C1A13 STOP LAMP RELAY

[ICC]

< DTC/CIRCUIT DIAGNOSIS >

Is the inspection result normal?

YES >> GO TO 13.

NO >> Replace ICC sensor integrated unit. Refer to [CCS-135. "Exploded View"](#).

13.CHECK ICC BRAKE HOLD RELAY POWER SUPPLY CIRCUIT

1. Turn ignition switch OFF.
2. Check voltage between ICC brake hold relay harness connector and ground.

Terminals		Voltage (Approx.)
(+)	(-)	
ICC brake hold relay		Ground
Connector	Terminal	
E51	3	
		Battery voltage

Is the inspection result normal?

YES >> GO TO 14.

NO >> Repair or replace ICC brake hold relay power supply circuit.

14.CHECK HARNESS BETWEEN ICC BRAKE HOLD RELAY AND ECM

1. Disconnect ECM, rear combination lamp and high-mounted stop lamp connector.
2. Check continuity between ICC brake hold relay harness connector and ECM harness connector.

ICC brake hold relay		ECM		Continuity
Connector	Terminal	Connector	Terminal	
E51	5	M107	122	Existed

3. Check continuity between ICC brake hold relay harness connector and ground.

ICC brake hold relay		Ground	Continuity
Connector	Terminal		
E51	5		Not existed

Is the inspection result normal?

YES >> GO TO 15.

NO >> Repair the harnesses or connectors.

15.CHECK ICC BRAKE HOLD RELAY

1. Connect ECM, rear combination lamp and high-mounted stop lamp connector and ICC brake hold relay.
2. Disconnect stop lamp switch connector.
3. Turn ignition switch ON.
4. Perform "STOP LAMP" on "Active Test" of "ICC", and then check the stop lamp for illumination.

Is the inspection result normal?

YES >> GO TO 16.

NO >> Replace ICC brake hold relay.

16.CHECK STOP LAMP SWITCH WITH ABS DATA MONITOR

Check that "STOP LAMP SW" operate normally in "DATA MONITOR" of "ABS".

Is the inspection result normal?

YES >> GO TO 21.

NO >> GO TO 17.

17.CHECK STOP LAMP SWITCH INSTALLATION

1. Turn ignition switch OFF.
2. Check stop lamp switch for correct installation. Refer to [BR-8. "Inspection and Adjustment"](#).

Is the inspection result normal?

YES >> GO TO 18.

C1A13 STOP LAMP RELAY

[ICC]

< DTC/CIRCUIT DIAGNOSIS >

NO >> Adjust stop lamp switch installation. Refer to [BR-8, "Inspection and Adjustment"](#).

18. CHECK STOP LAMP SWITCH

1. Disconnect stop lamp switch connector.
2. Check stop lamp switch. Refer to [CCS-58, "Component Inspection \(Stop Lamp Switch\)"](#).

Is the inspection result normal?

YES >> GO TO 19.

NO >> Replace stop lamp switch.

19. CHECK STOP LAMP SWITCH POWER SUPPLY CIRCUIT

1. Turn ignition switch ON.
2. Check voltage between stop lamp switch harness connector and ground.

Terminals		Voltage (Approx.)
(+)	(-)	
Stop lamp switch		Battery voltage
Connector	Terminal	
E110	1	

Is the inspection result normal?

YES >> GO TO 20.

NO >> Repair or replace stop lamp switch power supply circuit.

20. CHECK HARNESS BETWEEN STOP LAMP SWITCH AND ABS ACTUATOR AND ELECTRIC UNIT (CONTROL UNIT)

1. Turn ignition switch OFF.
2. Disconnect ABS actuator and electric unit (control unit) connector.
3. Check for continuity between stop lamp switch harness connector and ABS actuator and electric unit (control unit) harness connector.

Stop lamp switch		ABS actuator and electric unit (control unit)		Continuity
Connector	Terminal	Connector	Terminal	
E110	2	E41	30	Existed

Is the inspection result normal?

YES >> GO TO 22.

NO >> Repair the harnesses or connectors.

21. PERFORM SELF-DIAGNOSIS OF ECM

1. Connect all connectors again if the connectors are disconnected.
2. Turn ignition switch ON.
3. Perform "All DTC Reading".
4. Check if any DTC is detected in "Self Diagnostic Result" of "ENGINE". Refer to [EC-548, "DTC Index"](#).

Is any DTC detected?

YES >> Repair or replace the malfunctioning parts identified by the self-diagnosis result.

NO >> GO TO 22.

22. PERFORM SELF-DIAGNOSIS OF ABS ACTUATOR AND ELECTRIC UNIT (CONTROL UNIT)

1. Connect all connectors again if the connectors are disconnected.
2. Turn ignition switch ON.
3. Perform "All DTC Reading".
4. Check if any DTC is detected in "Self Diagnostic Result" of "ABS". Refer to [BRC-95, "DTC Index"](#).

Is any DTC detected?

YES >> Repair or replace the malfunctioning parts identified by the self-diagnosis result.

NO >> Replace ICC sensor integrated unit. Refer to [CCS-135, "Exploded View"](#).

C1A13 STOP LAMP RELAY

< DTC/CIRCUIT DIAGNOSIS >

[ICC]

Component Inspection

INFOID:000000005622567

1. CHECK ICC BRAKE HOLD RELAY

Apply battery voltage to ICC brake hold relay terminals 1 and 2, and then check for continuity under the following conditions.

Terminal	Condition	Continuity	
3	5	When the battery voltage is applied	Existed
		When the battery voltage is not applied	Not existed

Is the inspection result normal?

- YES >> INSPECTION END
- NO >> Replace ICC brake hold relay.

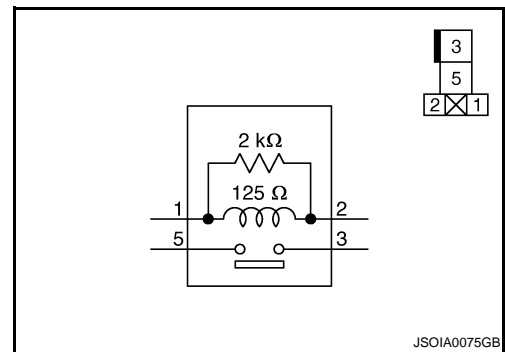

Special Repair Requirement

INFOID:000000005622568

DESCRIPTION

Perform the action test after adjusting the laser beam aiming of ICC sensor integrated unit when the following operation is performed.

- Removal and installation of ICC sensor integrated unit
- Replacement of ICC sensor integrated unit

SPECIAL REPAIR REQUIREMENT

1. LASER BEAM AIMING ADJUSTMENT OF ICC SENSOR INTEGRATED UNIT

Adjust the laser beam aiming of the ICC sensor integrated unit. Refer to [CCS-6, "LASER BEAM AIMING ADJUSTMENT : Description"](#).

>> GO TO 2.

2. CHECK ICC SYSTEM

1. Erase the "Self Diagnostic Result", and then perform "All DTC Reading" again after performing the action test. (Refer to [CCS-11, "ACTION TEST : Description"](#) for action test.)
2. Check that the ICC system is normal.

>> WORK END

A
B
C
D
E
F
G
H
I
J
K
L
M
N
P

CCS

C1A14 ECM

Description

INFOID:000000005622569

- ECM transmits the accelerator pedal position signal, ICC brake switch signal, stop lamp switch signal, ICC steering switch signal, etc. to ICC sensor integrated unit via CAN communication.
- ECM controls the electric throttle control actuator based on the engine torque demand received from the ICC sensor integrated unit via CAN communication.

DTC Logic

INFOID:000000005622570

DTC DETECTION LOGIC

DTC (On board display)	Trouble diagnosis name	DTC detecting condition	Possible causes
C1A14 (14)	ECM CIRCUIT	If ECM is malfunctioning	<ul style="list-style-type: none"> • Accelerator pedal position sensor • ECM • ICC sensor integrated unit

NOTE:

If DTC "C1A14" is detected along with DTC "U1000", first diagnose the DTC "U1000". Refer to [CCS-99. "DTC Logic"](#).

1. PERFORM DTC CONFIRMATION PROCEDURE

1. Start the engine.
2. Operate the ICC system and drive.
 - CAUTION:**
 - Always drive safely.**
3. Stop the vehicle.
4. Perform "All DTC Reading" with CONSULT-III.
5. Check if the "C1A14" is detected as the current malfunction in "Self Diagnostic Result" of "ICC".

Is "C1A14" detected as the current malfunction?

- YES >> Refer to [CCS-70. "Diagnosis Procedure"](#).
 NO >> Refer to [GI-37. "Intermittent Incident"](#).

Diagnosis Procedure

INFOID:000000005622571

1. CHECK SELF-DIAGNOSIS RESULTS

Check if "U1000" is detected other than "C1A14" in "Self Diagnostic Result" of "ICC".

Is "U1000" detected?

- YES >> Perform the CAN communication system inspection. Repair or replace the malfunctioning parts.
 Refer to [CCS-99. "DTC Logic"](#).
 NO >> GO TO 2.

2. PERFORM SELF-DIAGNOSIS OF ECM

Check if any DTC is detected in "Self Diagnostic Result" of "ENGINE".

Is any DTC detected?

- YES >> Perform diagnosis on the detected DTC and repair or replace the malfunctioning parts. Refer to [EC-548. "DTC Index"](#).
 NO >> Replace the ICC sensor integrated unit. Refer to [CCS-135. "Exploded View"](#).

Special Repair Requirement

INFOID:000000005622572

DESCRIPTION

Perform the action test after adjusting the laser beam aiming of ICC sensor integrated unit when the following operation is performed.

- Removal and installation of ICC sensor integrated unit
- Replacement of ICC sensor integrated unit

SPECIAL REPAIR REQUIREMENT

1.LASER BEAM AIMING ADJUSTMENT OF ICC SENSOR INTEGRATED UNIT

A

Adjust the laser beam aiming of the ICC sensor integrated unit. Refer to [CCS-6. "LASER BEAM AIMING ADJUSTMENT : Description"](#).

B

>> GO TO 2.

C

2.CHECK ICC SYSTEM

1. Erase the "Self Diagnostic Result", and then perform "All DTC Reading" again after performing the action test. (Refer to [CCS-11. "ACTION TEST : Description"](#) for action test.)
2. Check that the ICC system is normal.

D

>> WORK END

E

F

G

H

I

J

K

L

M

N

CCS

P

C1A15 GEAR POSITION

< DTC/CIRCUIT DIAGNOSIS >

[ICC]

C1A15 GEAR POSITION

Description

INFOID:000000005622573

ICC sensor integrated unit judges the gear position based on the following signals.

- Current gear position signal transmitted from TCM via CAN communication.
- Value of gear ratio calculated from input speed signal transmitted from TCM via CAN communication.
- Value of gear ratio calculated from the vehicle speed signal transmitted from ABS actuator and electric unit (control unit) via CAN communication.

DTC Logic

INFOID:000000005622574

DTC DETECTION LOGIC

DTC (On board display)	Trouble diagnosis name	DTC detecting condition	Possible causes
C1A15 (15)	GEAR POSITION	If a mismatch occurs between a current gear position signal transmitted from TCM via CAN communication and the gear position calculated by ICC sensor integrated unit	<ul style="list-style-type: none">• Input speed sensor• Vehicle speed sensor A/T (output speed sensor)• TCM

NOTE:

If DTC "C1A15" is detected along with DTC "U1000", "C1A03" or "C1A04", first diagnose the DTC "U1000", "C1A03" or "C1A04".

- Refer to [CCS-99, "DTC Logic"](#) for DTC "U1000".
- Refer to [CCS-47, "DTC Logic"](#) for DTC "C1A03".
- Refer to [CCS-50, "DTC Logic"](#) for DTC "C1A04".

DTC CONFIRMATION PROCEDURE

1. PERFORM DTC CONFIRMATION PROCEDURE

1. Start the engine.
2. Turn the MAIN switch of ICC system ON.
3. Drive the vehicle at 10 km/h (6 MPH) or faster for approximately 15 minutes or more.

CAUTION:

Always drive safely.

4. Stop the vehicle.
5. Perform "All DTC Reading" with CONSULT-III.
6. Check if "C1A15" is detected as the current malfunction in the "Self Diagnostic Result" of "ICC".

Is "C1A15" detected as the current malfunction?

YES >> Refer to [CCS-72, "Diagnosis Procedure"](#).

NO >> Refer to [GI-37, "Intermittent Incident"](#).

Diagnosis Procedure

INFOID:000000005622575

1. CHECK SELF-DIAGNOSIS RESULTS

Check if "C1A03", "C1A04" or "U1000" is detected other than "C1A15" in "Self Diagnostic Result" of "ICC".

Is any DTC detected?

YES >> Perform diagnosis on the detected DTC and repair or replace the malfunctioning parts. Refer to [CCS-116, "DTC Index"](#).

NO >> GO TO 2.

2. CHECK VEHICLE SPEED SIGNAL

Check that "VHCL SPEED SE" operates normally in "DATA MONITOR" of "ICC".

CAUTION:

Be careful of the vehicle speed.

Is the inspection result normal?

YES >> GO TO 3.

NO >> GO TO 7.

C1A15 GEAR POSITION

< DTC/CIRCUIT DIAGNOSIS >

[ICC]

3.CHECK GEAR POSITION

Check that "GEAR" operates normally in "DATA MONITOR" of "ICC".

CAUTION:

Be careful of the vehicle speed.

Is the inspection result normal?

YES >> GO TO 5.

NO >> GO TO 4.

4.CHECK GEAR POSITION SIGNAL

Check that "GEAR" operates normally in "DATA MONITOR" of "TRANSMISSION".

Is the inspection result normal?

YES >> GO TO 5.

NO >> GO TO 6.

5.CHECK INPUT SPEED SENSOR SIGNAL

Check that "INPUT SPEED" operates normally in "DATA MONITOR" of "TRANSMISSION".

Is the inspection result normal?

YES >> Replace the ICC sensor integrated unit. Refer to [CCS-135, "Exploded View"](#).

NO >> GO TO 6.

6.CHECK TCM SELF-DIAGNOSIS RESULTS

1. Perform "All DTC Reading".

2. Check if any DTC is detected in "Self Diagnostic Result" of "TRANSMISSION".

Is any DTC detected?

YES >> Perform diagnosis on the detected DTC and repair or replace the malfunctioning parts. Refer to [TM-253, "DTC Index"](#).

NO >> Replace the ICC sensor integrated unit. Refer to [CCS-135, "Exploded View"](#).

7.CHECK ABS ACTUATOR AND ELECTRIC UNIT (CONTROL UNIT) SELF-DIAGNOSIS RESULTS

1. Perform "All DTC Reading".

2. Check if any DTC is detected in "Self Diagnostic Result" of "ABS".

Is any DTC detected?

YES >> Perform diagnosis on the detected DTC and repair or replace the malfunctioning parts. Refer to [BRC-95, "DTC Index"](#).

NO >> Replace the ICC sensor integrated unit. Refer to [CCS-135, "Exploded View"](#).

Special Repair Requirement

INFOID:0000000005622576

DESCRIPTION

Perform the action test after adjusting the laser beam aiming of ICC sensor integrated unit when the following operation is performed.

- Removal and installation of ICC sensor integrated unit
- Replacement of ICC sensor integrated unit

SPECIAL REPAIR REQUIREMENT

1.LASER BEAM AIMING ADJUSTMENT OF ICC SENSOR INTEGRATED UNIT

Adjust the laser beam aiming of the ICC sensor integrated unit. Refer to [CCS-6, "LASER BEAM AIMING ADJUSTMENT : Description"](#).

>> GO TO 2.

2.CHECK ICC SYSTEM

1. Erase the "Self Diagnostic Result", and then perform "All DTC Reading" again after performing the action test. (Refer to [CCS-11, "ACTION TEST : Description"](#) for action test.)
2. Check that the ICC system is normal.

C1A15 GEAR POSITION

< DTC/CIRCUIT DIAGNOSIS >

[ICC]

>> WORK END

C1A16 RADAR STAIN

< DTC/CIRCUIT DIAGNOSIS >

[ICC]

C1A16 RADAR STAIN

Description

INFOID:000000005622577

ICC sensor integrated unit detects the reflected light from the vehicle ahead by irradiating a laser beam forward. It calculates the distance from and relative speed with the vehicle ahead based on the detected signal.

DTC Logic

INFOID:000000005622578

DTC DETECTION LOGIC

DTC (On board display)	Trouble diagnosis name	DTC detecting condition	Possible causes
C1A16 (16)	RADAR STAIN	If any stain occurs to ICC sensor integrated unit body window	<ul style="list-style-type: none">• Stain or foreign materials is deposited• Cracks or scratches exist

NOTE:

DTC "C1A16" may be detected under the following conditions. (Explain to the customer about the difference between the contamination detection function and the indication when the malfunction is detected and tell them "This is not malfunction".)

- When contamination or foreign materials adhere to the ICC sensor integrated unit body window
- When driving while it is snowing or when frost forms on the ICC sensor integrated unit body window
- When ICC sensor integrated unit body window is temporarily fogged

Diagnosis Procedure

INFOID:000000005622579

1. VISUAL CHECK 1

Check ICC sensor integrated unit body window for contamination and foreign materials.

Does contamination or foreign materials adhere?

- YES >> Wipe out the contamination and foreign materials from the ICC sensor integrated unit body window.
- NO >> GO TO 2.

2. VISUAL CHECK 2

Check ICC sensor integrated unit body window for cracks and scratches.

Is it found?

- YES >> Replace the ICC sensor integrated unit. Refer to [CCS-135. "Exploded View"](#).
- NO >> GO TO 3.

3. INTERVIEW

1. Ask if there is any trace of contamination or foreign materials adhering to the ICC sensor integrated unit body window.
2. Ask if ICC sensor integrated unit body window was frosted during driving or if vehicle was driven in snow.
3. Ask if ICC sensor integrated unit body window was temporarily fogged. (Windshield glass may also tend to fog, etc.)

What is the result of the interview with the customer?

- YES >> Explain to the customer about the difference between the contamination detection function and the indication when the malfunction is detected and tell them "This is not malfunction".
- NO >> Replace the ICC sensor integrated unit. Refer to [CCS-135. "Exploded View"](#).

Special Repair Requirement

INFOID:000000005622580

DESCRIPTION

Perform the action test after adjusting the laser beam aiming of ICC sensor integrated unit when the following operation is performed.

- Removal and installation of ICC sensor integrated unit
- Replacement of ICC sensor integrated unit

A
B
C
D
E
F
G
H
I
J
K
L
M
N
P

CCS

C1A16 RADAR STAIN

< DTC/CIRCUIT DIAGNOSIS >

[ICC]

SPECIAL REPAIR REQUIREMENT

1.LASER BEAM AIMING ADJUSTMENT OF ICC SENSOR INTEGRATED UNIT

Adjust the laser beam aiming of the ICC sensor integrated unit. Refer to [CCS-6. "LASER BEAM AIMING ADJUSTMENT : Description"](#).

>> GO TO 2.

2.CHECK ICC SYSTEM

1. Erase the "Self Diagnostic Result", and then perform "All DTC Reading" again after performing the action test. (Refer to [CCS-11. "ACTION TEST : Description"](#) for action test.)
2. Check that the ICC system is normal.

>> WORK END

C1A18 LASER AIMING INCMP

< DTC/CIRCUIT DIAGNOSIS >

[ICC]

C1A18 LASER AIMING INCMP

Description

INFOID:000000005622581

Always perform the laser beam aiming adjustment after replacing the ICC sensor integrated unit.

DTC Logic

INFOID:000000005622582

DTC DETECTION LOGIC

DTC (On board display)	Trouble diagnosis name	DTC detecting condition	Possible causes
C1A18 (18)	LASER AIMING IN- CMP	Laser beam aiming of ICC sensor integrated unit is not adjusted	<ul style="list-style-type: none">No laser beam aiming adjustment is performedLaser beam aiming adjustment has been interrupted

DTC CONFIRMATION PROCEDURE

1.PERFORM DTC CONFIRMATION PROCEDURE

1. Start the engine.
2. Turn the MAIN switch of ICC system ON.
3. Perform "All DTC Reading" with CONSULT-III.
4. Check if the "C1A18" is detected as the current malfunction in "Self Diagnostic Result" of "ICC".

Is "C1A18" detected as the current malfunction?

- YES >> Refer to [CCS-77, "Diagnosis Procedure"](#).
NO >> INSPECTION END

Diagnosis Procedure

INFOID:000000005622583

1.AJUST LASER BEAM AIMING

1. Adjust the laser beam aiming. Refer to [CCS-6, "LASER BEAM AIMING ADJUSTMENT : Description"](#).
2. Erase All self-diagnosis results with CONSULT-III.
3. Perform "All DTC Reading".
4. Check if the "C1A18" is detected in "Self Diagnostic Result" of "ICC".

Is "C1A18" detected?

- YES >> Replace the ICC sensor integrated unit. Refer to [CCS-135, "Exploded View"](#).
NO >> INSPECTION END

Special Repair Requirement

INFOID:000000005622584

DESCRIPTION

Perform the action test after adjusting the laser beam aiming of ICC sensor integrated unit when the following operation is performed.

- Removal and installation of ICC sensor integrated unit
- Replacement of ICC sensor integrated unit

SPECIAL REPAIR REQUIREMENT

1.LASER BEAM AIMING ADJUSTMENT OF ICC SENSOR INTEGRATED UNIT

Adjust the laser beam aiming of the ICC sensor integrated unit. Refer to [CCS-6, "LASER BEAM AIMING ADJUSTMENT : Description"](#).

>> GO TO 2.

2.CHECK ICC SYSTEM

C1A18 LASER AIMING INCOMP

< DTC/CIRCUIT DIAGNOSIS >

[ICC]

1. Erase the "Self Diagnostic Result", and then perform "All DTC Reading" again after performing the action test. (Refer to [CCS-11, "ACTION TEST : Description"](#) for action test.)
2. Check that the ICC system is normal.

>> WORK END

C1A21 UNIT HIGH TEMP

< DTC/CIRCUIT DIAGNOSIS >

[ICC]

C1A21 UNIT HIGH TEMP

Description

INFOID:0000000005622585

ICC sensor integrated unit integrates the temperature sensor.

DTC Logic

INFOID:0000000005622586

DTC DETECTION LOGIC

DTC (On board display)	Trouble diagnosis name	DTC detecting condition	Possible causes
C1A21 (21)	UNIT HIGH TEMP	If the temperature sensor (integrated in the ICC sensor integrated unit) detects a high temperature	Temperature around ICC sensor integrated unit is excessively high

DTC CONFIRMATION PROCEDURE

1. PERFORM DTC CONFIRMATION PROCEDURE

1. Turn the ignition switch OFF.
2. Wait for 10 minutes or more to cool the ICC sensor integrated unit.
3. Start the engine.
4. Turn the MAIN switch of ICC system ON.
5. Perform "All DTC Reading" with CONSULT-III.
6. Check if the "C1A21" is detected as the current malfunction in "Self Diagnostic Result" of "ICC".

Is "C1A21" detected as the current malfunction?

- YES >> Refer to [CCS-79, "Diagnosis Procedure"](#).
NO >> Refer to [GI-37, "Intermittent Incident"](#).

Diagnosis Procedure

INFOID:0000000005622587

1. CHECK ENGINE COOLING SYSTEM

Check for any malfunctions in engine cooling system.

Is engine cooling system normal?

- YES >> Replace the ICC sensor integrated unit. Refer to [CCS-135, "Exploded View"](#).
NO >> Repair engine cooling system.

Special Repair Requirement

INFOID:0000000005622588

DESCRIPTION

Perform the action test after adjusting the laser beam aiming of ICC sensor integrated unit when the following operation is performed.

- Removal and installation of ICC sensor integrated unit
- Replacement of ICC sensor integrated unit

SPECIAL REPAIR REQUIREMENT

1. LASER BEAM AIMING ADJUSTMENT OF ICC SENSOR INTEGRATED UNIT

Adjust the laser beam aiming of the ICC sensor integrated unit. Refer to [CCS-6, "LASER BEAM AIMING ADJUSTMENT : Description"](#).

>> GO TO 2.

2. CHECK ICC SYSTEM

1. Erase the "Self Diagnostic Result", and then perform "All DTC Reading" again after performing the action test. (Refer to [CCS-11, "ACTION TEST : Description"](#) for action test.)
2. Check that the ICC system is normal.

C1A21 UNIT HIGH TEMP

< DTC/CIRCUIT DIAGNOSIS >

[ICC]

>> WORK END

C1A24 NP RANGE

< DTC/CIRCUIT DIAGNOSIS >

[ICC]

C1A24 NP RANGE

Description

INFOID:000000005622589

ICC sensor integrated unit judges the NP position status from the shift position signal and current gear position signal received from TCM via CAN communication.

DTC Logic

INFOID:000000005622590

DTC DETECTION LOGIC

DTC (On board display)	Trouble diagnosis name	DTC detecting condition	Possible causes
C1A24 (24)	NP RANGE	If the shift position signal and the current gear position signal, transmitted from TCM via CAN communication, are inconsistent	<ul style="list-style-type: none">• TCM• Transmission range switch

NOTE:

If DTC "C1A24" is detected along with DTC "U1000", first diagnose the DTC "U1000". Refer to [CCS-99, "DTC Logic"](#).

DTC CONFIRMATION PROCEDURE

1. CHECK DTC REPRODUCE (1)

1. Start the engine.
2. Turn the MAIN switch of ICC system ON.
3. Wait for approximately 5 minutes or more after shifting the selector lever to "P" position.
4. Perform "All DTC Reading" with CONSULT-III.
5. Check if the "C1A24" is detected as the current malfunction in "Self Diagnostic Result" of "ICC".

Is "C1A24" detected as the current malfunction?

- YES >> Refer to [CCS-81, "Diagnosis Procedure"](#).
NO >> GO TO 2.

2. CHECK DTC REPRODUCE (2)

1. Wait for approximately 5 minutes or more after shifting the selector lever to "N" position.
2. Perform "All DTC Reading".
3. Check if the "C1A24" is detected as the current malfunction in "Self Diagnostic Result" of "ICC".

Is "C1A24" detected as the current malfunction?

- YES >> Refer to [CCS-81, "Diagnosis Procedure"](#).
NO >> Refer to [GI-37, "Intermittent Incident"](#).

Diagnosis Procedure

INFOID:000000005622591

1. CHECK SELF-DIAGNOSIS RESULTS

Check if "U1000" is detected other than "C1A24" in "Self Diagnostic Result" of "ICC".

Is "U1000" detected?

- YES >> Perform the CAN communication system inspection. Repair or replace the malfunctioning parts.
Refer to [CCS-99, "DTC Logic"](#).
NO >> GO TO 2.

2. CHECK NP POSITION SWITCH SIGNAL

Check that "NP RANGE SW" operates normally in "DATA MONITOR" of "ICC".

Is the inspection result normal?

- YES >> GO TO 3.
NO >> Replace the ICC sensor integrated unit. Refer to [CCS-135, "Exploded View"](#).

3. CHECK TCM DATA MONITOR

Check that "SLCT LVR POSI" operates normally in "DATA MONITOR" of "TRANSMISSION".

A
B
C
D
E
F
G
H
I
J
K
L
M
N
P

CCS

< DTC/CIRCUIT DIAGNOSIS >

Is the inspection result normal?

- YES >> Replace the ICC sensor integrated unit. Refer to [CCS-135, "Exploded View"](#).
NO >> GO TO 4.

4.PERFORM TCM SELF-DIAGNOSIS

1. Perform "All DTC Reading".
2. Check if any DTC is detected in "Self Diagnostic Result" of "TRANSMISSION".

Is any DTC detected?

- YES >> Perform diagnosis on the detected DTC and repair or replace the malfunctioning parts. Refer to [TM-253, "DTC Index"](#).
NO >> Replace the ICC sensor integrated unit. Refer to [CCS-135, "Exploded View"](#).

Special Repair Requirement

INFOID:000000005622592

DESCRIPTION

Perform the action test after adjusting the laser beam aiming of ICC sensor integrated unit when the following operation is performed.

- Removal and installation of ICC sensor integrated unit
- Replacement of ICC sensor integrated unit

SPECIAL REPAIR REQUIREMENT

1.LASER BEAM AIMING ADJUSTMENT OF ICC SENSOR INTEGRATED UNIT

Adjust the laser beam aiming of the ICC sensor integrated unit. Refer to [CCS-6, "LASER BEAM AIMING ADJUSTMENT : Description"](#).

>> GO TO 2.

2.CHECK ICC SYSTEM

1. Erase the "Self Diagnostic Result", and then perform "All DTC Reading" again after performing the action test. (Refer to [CCS-11, "ACTION TEST : Description"](#) for action test.)
2. Check that the ICC system is normal.

>> WORK END

C1A26 ECD MODE MALFUNCTION

< DTC/CIRCUIT DIAGNOSIS >

[ICC]

C1A26 ECD MODE MALFUNCTION

Description

INFOID:000000005622593

ECD (ELECTRONICALLY CONTROLLED DECELERATION)

- Receives deceleration degree commandment value signal from ICC sensor integrated unit, and controls brake fluid pressure with the motor [built in ABS actuator and electric unit (control unit)].
- ECD control-related signals are transmitted by ABS actuator and electric unit (control unit) to ICC sensor integrated unit via CAN communication.

DTC Logic

INFOID:000000005622594

DTC DETECTION LOGIC

DTC No. (On board display)	Trouble diagnosis name	DTC detecting condition	Possible cause
C1A26 (26)	ECD MODE MALF	If an abnormal condition occurs with ECD system	ABS actuator and electric unit (control unit)

NOTE:

If DTC "C1A26" is detected along with DTC "U1000", "U0415", or "U0121", first diagnose the DTC "U1000", "U0415", or "U0121".

- DTC "U1000": Refer to [CCS-99, "DTC Logic"](#).
- DTC "U0415": Refer to [CCS-97, "DTC Logic"](#).
- DTC "U0121": Refer to [CCS-91, "DTC Logic"](#).

DTC CONFIRMATION PROCEDURE

1. PERFORM DTC CONFIRMATION PROCEDURE

1. Start the engine.
2. Wait for approximately 1 minute after turning the MAIN switch of ICC system ON.
3. Perform "All DTC Reading" with CONSULT-III.
4. Check if the "C1A26" is detected as the current malfunction in "Self Diagnostic Result" of "ICC".

Is "C1A26" detected as the current malfunction?

- YES >> Refer to [CCS-83, "Diagnosis Procedure"](#).
- NO >> Refer to [GI-37, "Intermittent Incident"](#).

Diagnosis Procedure

INFOID:000000005622595

1. CHECK SELF-DIAGNOSIS RESULTS

Check if "U1000", "U0415", or "U0121" is detected other than "C1A26" in "Self Diagnostic Result" of "ICC".

Is any DTC detected?

- YES >> Perform diagnosis on the detected DTC and repair or replace the malfunctioning parts. Refer to [CCS-116, "DTC Index"](#).
- NO >> GO TO 2.

2. PERFORM SELF-DIAGNOSIS OF ABS ACTUATOR AND ELECTRIC UNIT (CONTROL UNIT)

Check if any DTC is detected in "Self Diagnostic Result" of "ABS".

Is any DTC detected?

- YES >> Perform diagnosis on the detected DTC and repair or replace the malfunctioning parts. Refer to [BRC-95, "DTC Index"](#).
- NO >> Replace ICC sensor integrated unit. Refer to [CCS-135, "Exploded View"](#).

Special Repair Requirement

INFOID:000000005622596

DESCRIPTION

A
B
C
D
E
F
G
H
I
J
K
L
M
N
P



C1A26 ECD MODE MALFUNCTION

[ICC]

< DTC/CIRCUIT DIAGNOSIS >

Perform the action test after adjusting the laser beam aiming of ICC sensor integrated unit when the following operation is performed.

- Removal and installation of ICC sensor integrated unit
- Replacement of ICC sensor integrated unit

SPECIAL REPAIR REQUIREMENT

1.LASER BEAM AIMING ADJUSTMENT OF ICC SENSOR INTEGRATED UNIT

Adjust the laser beam aiming of the ICC sensor integrated unit. Refer to [CCS-6, "LASER BEAM AIMING ADJUSTMENT : Description"](#).

>> GO TO 2.

2.CHECK ICC SYSTEM

1. Erase the "Self Diagnostic Result", and then perform "All DTC Reading" again after performing the action test. (Refer to [CCS-11, "ACTION TEST : Description"](#) for action test.)
2. Check that the ICC system is normal.

>> WORK END

C1A27 ECD POWER SUPPLY CIRCUIT

< DTC/CIRCUIT DIAGNOSIS >

[ICC]

C1A27 ECD POWER SUPPLY CIRCUIT

Description

INFOID:000000005622597

ECD (ELECTRONICALLY CONTROLLED DECELERATION)

- Receives deceleration degree commandment value signal from ICC sensor integrated unit, and controls brake fluid pressure with the motor [built in ABS actuator and electric unit (control unit)].
- ECD control-related signals are transmitted by ABS actuator and electric unit (control unit) to ICC sensor integrated unit via CAN communication.

DTC Logic

INFOID:000000005622598

DTC DETECTION LOGIC

DTC No. (On board display)	Trouble diagnosis name	DTC detecting condition	Possible cause
C1A27 (27)	ECD PWR SUPPLY CIR	ECD system power supply voltage is excessively low	<ul style="list-style-type: none">• ABS actuator and electric unit (control unit) power supply circuit• ABS actuator and electric unit (control unit)

NOTE:

If DTC "C1A27" is detected along with DTC "U1000", "U0415", or "U0121" first diagnose the DTC "U1000", "U0415", or "U0121".

- DTC "U1000": Refer to [CCS-99, "DTC Logic"](#).
- DTC "U0415": Refer to [CCS-97, "DTC Logic"](#).
- DTC "U0121": Refer to [CCS-91, "DTC Logic"](#).

DTC CONFIRMATION PROCEDURE

1. PERFORM DTC CONFIRMATION PROCEDURE

1. Start the engine.
2. Wait for approximately 1 minute after turning the MAIN switch of ICC system ON.
3. Perform "All DTC Reading" with CONSULT-III.
4. Check if the "C1A27" is detected as the current malfunction in "Self Diagnostic Result" of "ICC".

Is "C1A27" detected as the current malfunction?

- YES >> Refer to [CCS-85, "Diagnosis Procedure"](#).
NO >> Refer to [GI-37, "Intermittent Incident"](#).

Diagnosis Procedure

INFOID:000000005622599

1. CHECK SELF-DIAGNOSIS RESULTS

Check if "U1000", "U0415" or "U0121" is detected other than "C1A27" in "Self Diagnostic Result" of "ICC".

Is any DTC detected?

- YES >> Perform diagnosis on the detected DTC and repair or replace the malfunctioning parts. Refer to [CCS-116, "DTC Index"](#).
NO >> GO TO 2.

2. CHECK POWER SUPPLY CIRCUIT OF ABS ACTUATOR AND ELECTRIC UNIT (CONTROL UNIT)

Check power supply circuit of ABS actuator and electric unit (control unit). Refer to [BRC-73, "Diagnosis Procedure"](#).

Is the inspection result normal?

- YES >> Perform self-diagnosis of ABS actuator and electric unit (control unit). Refer to [BRC-95, "DTC Index"](#).
NO >> Repair the harnesses or connectors.

C1A27 ECD POWER SUPPLY CIRCUIT

< DTC/CIRCUIT DIAGNOSIS >

[ICC]

Special Repair Requirement

INFOID:000000005622600

DESCRIPTION

Perform the action test after adjusting the laser beam aiming of ICC sensor integrated unit when the following operation is performed.

- Removal and installation of ICC sensor integrated unit
- Replacement of ICC sensor integrated unit

SPECIAL REPAIR REQUIREMENT

1.LASER BEAM AIMING ADJUSTMENT OF ICC SENSOR INTEGRATED UNIT

Adjust the laser beam aiming of the ICC sensor integrated unit. Refer to [CCS-6, "LASER BEAM AIMING ADJUSTMENT : Description"](#).

>> GO TO 2.

2.CHECK ICC SYSTEM

1. Erase the "Self Diagnostic Result", and then perform "All DTC Reading" again after performing the action test. (Refer to [CCS-11, "ACTION TEST : Description"](#) for action test.)
2. Check that the ICC system is normal.

>> WORK END

C1A33 CAN TRANSMISSION ERROR

< DTC/CIRCUIT DIAGNOSIS >

[ICC]

C1A33 CAN TRANSMISSION ERROR

Description

INFOID:000000005622601

ICC sensor integrated unit transmits the signal required by the ICC system control to ECM via CAN communication.

DTC Logic

INFOID:000000005622602

DTC DETECTION LOGIC

DTC (On board display)	Trouble diagnosis name	DTC detecting condition	Possible causes
C1A33 (33)	CAN TRANSMISSION ERROR	If an error occurs in the CAN communication signal that ICC sensor integrated unit transmits to ECM	ICC sensor integrated unit

NOTE:

If DTC "C1A33" is detected along with DTC "U1000", first diagnose the DTC "U1000". Refer to [CCS-99, "DTC Logic"](#).

DTC CONFIRMATION PROCEDURE

1. PERFORM DTC CONFIRMATION PROCEDURE

1. Start the engine.
2. Turn the MAIN switch of ICC system ON.
3. Perform "All DTC Reading" with CONSULT-III.
4. Check if the "C1A33" is detected as the current malfunction in "Self Diagnostic Result" of "ICC".

Is "C1A33" detected as the current malfunction?

- YES >> Refer to [CCS-87, "Diagnosis Procedure"](#).
NO >> Refer to [GI-37, "Intermittent Incident"](#).

Diagnosis Procedure

INFOID:000000005622603

1. CHECK SELF-DIAGNOSIS RESULTS

Check if "U1000" is detected other than "C1A33" in "Self Diagnostic Result" of "ICC".

Is "U1000" detected?

- YES >> Perform the CAN communication system inspection. Repair or replace the malfunctioning parts. Refer to [CCS-99, "DTC Logic"](#).
NO >> Replace the ICC sensor integrated unit. Refer to [CCS-135, "Exploded View"](#).

Special Repair Requirement

INFOID:000000005622604

DESCRIPTION

Perform the action test after adjusting the laser beam aiming of ICC sensor integrated unit when the following operation is performed.

- Removal and installation of ICC sensor integrated unit
- Replacement of ICC sensor integrated unit

SPECIAL REPAIR REQUIREMENT

1. LASER BEAM AIMING ADJUSTMENT OF ICC SENSOR INTEGRATED UNIT

Adjust the laser beam aiming of the ICC sensor integrated unit. Refer to [CCS-6, "LASER BEAM AIMING ADJUSTMENT : Description"](#).

>> GO TO 2.

2. CHECK ICC SYSTEM

A
B
C
D
E
F
G
H
I
J
K
L
M
N
P

C1A33 CAN TRANSMISSION ERROR

< DTC/CIRCUIT DIAGNOSIS >

[ICC]

1. Erase the "Self Diagnostic Result", and then perform "All DTC Reading" again after performing the action test. (Refer to [CCS-11, "ACTION TEST : Description"](#) for action test.)
2. Check that the ICC system is normal.

>> WORK END

C1A34 COMMAND ERROR

< DTC/CIRCUIT DIAGNOSIS >

[ICC]

C1A34 COMMAND ERROR

Description

INFOID:000000005622605

ICC sensor integrated unit transmits the command signal required for the ECM control via CAN communication.

DTC Logic

INFOID:000000005622606

DTC DETECTION LOGIC

DTC (On board display)	Trouble diagnosis name	DTC detecting condition	Possible causes
C1A34 (34)	COMMAND ERROR	If an error occurs in the command signal that ICC sensor integrated unit transmits to ECM via CAN communication	ICC sensor integrated unit

NOTE:

If DTC "C1A34" is detected along with DTC "U1000", first diagnose the DTC "U1000". Refer to [CCS-99, "DTC Logic"](#).

DTC CONFIRMATION PROCEDURE

1. PERFORM DTC CONFIRMATION PROCEDURE

1. Start the engine.
2. Operate the ICC system and drive.
CAUTION:
Always drive safely.
3. Stop the vehicle.
4. Perform "All DTC Reading" with CONSULT-III.
5. Check if the "C1A34" is detected as the current malfunction in "Self Diagnostic Result" of "ICC".

Is "C1A34" detected as the current malfunction?

- YES >> Refer to [CCS-89, "Diagnosis Procedure"](#).
NO >> Refer to [GI-37, "Intermittent Incident"](#).

Diagnosis Procedure

INFOID:000000005622607

1. CHECK SELF-DIAGNOSIS RESULTS

Check if "U1000" is detected other than "C1A34" in "Self Diagnostic Result" of "ICC".

Is "U1000" detected?

- YES >> Perform the CAN communication system inspection. Repair or replace the malfunctioning parts.
Refer to [CCS-99, "DTC Logic"](#).
NO >> Replace the ICC sensor integrated unit. Refer to [CCS-135, "Exploded View"](#).

Special Repair Requirement

INFOID:000000005622608

DESCRIPTION

Perform the action test after adjusting the laser beam aiming of ICC sensor integrated unit when the following operation is performed.

- Removal and installation of ICC sensor integrated unit
- Replacement of ICC sensor integrated unit

SPECIAL REPAIR REQUIREMENT

1. LASER BEAM AIMING ADJUSTMENT OF ICC SENSOR INTEGRATED UNIT

Adjust the laser beam aiming of the ICC sensor integrated unit. Refer to [CCS-6, "LASER BEAM AIMING ADJUSTMENT : Description"](#).

A
B
C
D
E
F
G
H
I
J
K
L
M
N
P

CCS

C1A34 COMMAND ERROR

< DTC/CIRCUIT DIAGNOSIS >

[ICC]

>> GO TO 2.

2.CHECK ICC SYSTEM

-
1. Erase the "Self Diagnostic Result", and then perform "All DTC Reading" again after performing the action test. (Refer to [CCS-11, "ACTION TEST : Description"](#) for action test.)
 2. Check that the ICC system is normal.

>> WORK END

U0121 VDC CAN 2

< DTC/CIRCUIT DIAGNOSIS >

[ICC]

U0121 VDC CAN 2

Description

INFOID:000000005622609

ABS actuator and electric unit (control unit) transmit the VDC system signal to ICC sensor integrated unit via CAN communication.

DTC Logic

INFOID:000000005622610

DTC DETECTION LOGIC

DTC (On board display)	Trouble diagnosis name	DTC detecting condition	Possible causes
U0121 (127)	VDC CAN CIR2	If ICC sensor integrated unit detects an error signal that is received from ABS actuator and electric unit (control unit) via CAN communication	ABS actuator and electric unit (control unit)

NOTE:

If DTC "U0121" is detected along with DTC "U1000", first diagnose the DTC "U1000". Refer to [CCS-99, "DTC Logic"](#).

DTC CONFIRMATION PROCEDURE

1. PERFORM DTC CONFIRMATION PROCEDURE

1. Start the engine.
2. Turn the MAIN switch of ICC system ON.
3. Perform "All DTC Reading" with CONSULT-III.
4. Check if the "U0121" is detected as the current malfunction in "Self Diagnostic Result" of "ICC".

Is "U0121" detected as the current malfunction?

- YES >> Refer to [CCS-91, "Diagnosis Procedure"](#).
NO >> Refer to [GI-37, "Intermittent Incident"](#).

Diagnosis Procedure

INFOID:000000005622611

1. CHECK SELF-DIAGNOSIS RESULTS

Check if "U1000" is detected other than "U0121" in "Self Diagnostic Result" of "ICC".

Is "U1000" detected?

- YES >> Perform the CAN communication system inspection. Repair or replace the malfunctioning parts. Refer to [CCS-99, "DTC Logic"](#).
NO >> GO TO 2.

2. CHECK ABS ACTUATOR AND ELECTRIC UNIT (CONTROL UNIT) SELF-DIAGNOSIS RESULTS

Check if any DTC is detected in "Self Diagnostic Result" of "ABS".

Is any DTC detected?

- YES >> Perform diagnosis on the detected DTC and repair or replace the malfunctioning parts. Refer to [BRC-95, "DTC Index"](#).
NO >> Replace the ICC sensor integrated unit. Refer to [CCS-135, "Exploded View"](#).

Special Repair Requirement

INFOID:000000005622612

DESCRIPTION

Perform the action test after adjusting the laser beam aiming of ICC sensor integrated unit when the following operation is performed.

- Removal and installation of ICC sensor integrated unit
- Replacement of ICC sensor integrated unit

SPECIAL REPAIR REQUIREMENT

A
B
C
D
E
F
G
H
I
J
K
L
M
N
P



1.LASER BEAM AIMING ADJUSTMENT OF ICC SENSOR INTEGRATED UNIT

Adjust the laser beam aiming of the ICC sensor integrated unit. Refer to [CCS-6. "LASER BEAM AIMING ADJUSTMENT : Description"](#).

>> GO TO 2.

2.CHECK ICC SYSTEM

1. Erase the "Self Diagnostic Result", and then perform "All DTC Reading" again after performing the action test. (Refer to [CCS-11. "ACTION TEST : Description"](#) for action test.)
2. Check that the ICC system is normal.

>> WORK END

U0401 ECM CAN 1

< DTC/CIRCUIT DIAGNOSIS >

[ICC]

U0401 ECM CAN 1

Description

INFOID:000000005622613

ECM transmits the signal related to engine control (ICC system) to ICC sensor integrated unit via CAN communication.

DTC Logic

INFOID:000000005622614

DTC DETECTION LOGIC

DTC (On board display)	Trouble diagnosis name	DTC detecting condition	Possible causes
U0401 (120)	ECM CAN CIR1	If ICC sensor integrated unit detects an error signal that is received from ECM via CAN communication	ECM

NOTE:

If DTC "U0401" is detected along with DTC "U1000", first diagnose the DTC "U1000". Refer to [CCS-99, "DTC Logic"](#).

DTC CONFIRMATION PROCEDURE

1. PERFORM DTC CONFIRMATION PROCEDURE

1. Start the engine.
2. Turn the MAIN switch of ICC system ON.
3. Perform "All DTC Reading" with CONSULT-III.
4. Check if the "U0401" is detected as the current malfunction in "Self Diagnostic Result" of "ICC".

Is "U0401" detected as the current malfunction?

- YES >> Refer to [CCS-93, "Diagnosis Procedure"](#).
 NO >> Refer to [GI-37, "Intermittent Incident"](#).

Diagnosis Procedure

INFOID:000000005622615

1. CHECK SELF-DIAGNOSIS RESULTS

Check if "U1000" is detected other than "U0401" in "Self Diagnostic Result" of "ICC".

Is "U1000" detected?

- YES >> Perform the CAN communication system inspection. Repair or replace the malfunctioning parts. Refer to [CCS-99, "DTC Logic"](#).
 NO >> GO TO 2.

2. CHECK ECM SELF-DIAGNOSIS RESULTS

Check if any DTC is detected in "Self Diagnostic Result" of "ENGINE".

Is any DTC detected?

- YES >> Perform diagnosis on the detected DTC and repair or replace the malfunctioning parts. Refer to [EC-548, "DTC Index"](#).
 NO >> Replace the ICC sensor integrated unit. Refer to [CCS-135, "Exploded View"](#).

Special Repair Requirement

INFOID:000000005622616

DESCRIPTION

Perform the action test after adjusting the laser beam aiming of ICC sensor integrated unit when the following operation is performed.

- Removal and installation of ICC sensor integrated unit
- Replacement of ICC sensor integrated unit

SPECIAL REPAIR REQUIREMENT

1. LASER BEAM AIMING ADJUSTMENT OF ICC SENSOR INTEGRATED UNIT

A
B
C
D
E
F
G
H
I
J
K
L
M
N
P

CCS

U0401 ECM CAN 1

< DTC/CIRCUIT DIAGNOSIS >

[ICC]

Adjust the laser beam aiming of the ICC sensor integrated unit. Refer to [CCS-6. "LASER BEAM AIMING ADJUSTMENT : Description"](#).

>> GO TO 2.

2.CHECK ICC SYSTEM

1. Erase the "Self Diagnostic Result", and then perform "All DTC Reading" again after performing the action test. (Refer to [CCS-11. "ACTION TEST : Description"](#) for action test.)
2. Check that the ICC system is normal.

>> WORK END

U0402 TCM CAN 1

< DTC/CIRCUIT DIAGNOSIS >

[ICC]

U0402 TCM CAN 1

Description

INFOID:0000000005622617

TCM transmits the signal related to A/T control to ICC sensor integrated unit via CAN communication.

DTC Logic

INFOID:0000000005622618

DTC DETECTION LOGIC

DTC (On board display)	Trouble diagnosis name	DTC detecting condition	Possible causes
U0402 (122)	TCM CAN CIRC1	If ICC sensor integrated unit detects an error signal that is received from TCM via CAN communication	TCM

NOTE:

If DTC "U0402" is detected along with DTC "U1000", first diagnose the DTC "U1000". Refer to [CCS-99, "DTC Logic"](#).

DTC CONFIRMATION PROCEDURE

1. PERFORM DTC CONFIRMATION PROCEDURE

1. Start the engine.
2. Turn the MAIN switch of ICC system ON.
3. Perform "All DTC Reading" with CONSULT-III.
4. Check if the "U0402" is detected as the current malfunction in "Self Diagnostic Result" of "ICC".

Is "U0402" detected as the current malfunction?

- YES >> Refer to [CCS-95, "Diagnosis Procedure"](#).
 NO >> Refer to [GI-37, "Intermittent Incident"](#).

Diagnosis Procedure

INFOID:0000000005622619

1. CHECK SELF-DIAGNOSIS RESULTS

Check if "U1000" is detected other than "U0402" in "Self Diagnostic Result" of "ICC".

Is "U1000" detected?

- YES >> Perform the CAN communication system inspection. Repair or replace the malfunctioning parts. Refer to [CCS-99, "DTC Logic"](#).
 NO >> GO TO 2.

2. CHECK TCM SELF-DIAGNOSIS RESULTS

Check if any DTC is detected in "Self Diagnostic Result" of "TRANSMISSION".

Is any DTC detected?

- YES >> Perform diagnosis on the detected DTC and repair or replace the malfunctioning parts. Refer to [TM-253, "DTC Index"](#).
 NO >> Replace the ICC sensor integrated unit. Refer to [CCS-135, "Exploded View"](#).

Special Repair Requirement

INFOID:0000000005622620

DESCRIPTION

Perform the action test after adjusting the laser beam aiming of ICC sensor integrated unit when the following operation is performed.

- Removal and installation of ICC sensor integrated unit
- Replacement of ICC sensor integrated unit

SPECIAL REPAIR REQUIREMENT

1. LASER BEAM AIMING ADJUSTMENT OF ICC SENSOR INTEGRATED UNIT

A
B
C
D
E
F
G
H
I
J
K
L
M
N
P



U0402 TCM CAN 1

< DTC/CIRCUIT DIAGNOSIS >

[ICC]

Adjust the laser beam aiming of the ICC sensor integrated unit. Refer to [CCS-6. "LASER BEAM AIMING ADJUSTMENT : Description"](#).

>> GO TO 2.

2.CHECK ICC SYSTEM

1. Erase the "Self Diagnostic Result", and then perform "All DTC Reading" again after performing the action test. (Refer to [CCS-11. "ACTION TEST : Description"](#) for action test.)
2. Check that the ICC system is normal.

>> WORK END

U0415 VDC CAN 1

< DTC/CIRCUIT DIAGNOSIS >

[ICC]

U0415 VDC CAN 1

Description

INFOID:000000005622621

ABS actuator and electric unit (control unit) transmits the signal related to the VDC system to ICC sensor integrated unit via CAN communication.

DTC Logic

INFOID:000000005622622

DTC DETECTION LOGIC

DTC (On board display)	Trouble diagnosis name	DTC detecting condition	Possible causes
U0415 (126)	VDC CAN CIR1	If ICC sensor integrated unit detects an error signal that is received from ABS actuator and electric unit (control unit) via CAN communication	ABS actuator and electric unit (control unit)

NOTE:

If DTC "U0415" is detected along with DTC "U1000", first diagnose the DTC "U1000". Refer to [CCS-99, "DTC Logic"](#).

DTC CONFIRMATION PROCEDURE

1. PERFORM DTC CONFIRMATION PROCEDURE

1. Start the engine.
2. Turn the MAIN switch of ICC system ON.
3. Perform "All DTC Reading" with CONSULT-III.
4. Check if the "U0415" is detected as the current malfunction in "Self Diagnostic Result" of "ICC".

Is "U0415" detected as the current malfunction?

- YES >> Refer to [CCS-97, "Diagnosis Procedure"](#).
NO >> Refer to [GI-37, "Intermittent Incident"](#).

Diagnosis Procedure

INFOID:000000005622623

1. CHECK SELF-DIAGNOSIS RESULTS

Check if "U1000" is detected other than "U0415" in "Self Diagnostic Result" of "ICC".

Is "U1000" detected?

- YES >> Perform the CAN communication system inspection. Repair or replace the malfunctioning parts. Refer to [CCS-99, "DTC Logic"](#).
NO >> GO TO 2.

2. CHECK ABS ACTUATOR AND ELECTRIC UNIT (CONTROL UNIT) SELF-DIAGNOSIS RESULTS

Check if any DTC is detected in "Self Diagnostic Result" of "ABS".

Is any DTC detected?

- YES >> Perform diagnosis on the detected DTC and repair or replace the malfunctioning parts. Refer to [TM-253, "DTC Index"](#).
NO >> Replace the ICC sensor integrated unit. Refer to [CCS-135, "Exploded View"](#).

Special Repair Requirement

INFOID:000000005622624

DESCRIPTION

Perform the action test after adjusting the laser beam aiming of ICC sensor integrated unit when the following operation is performed.

- Removal and installation of ICC sensor integrated unit
- Replacement of ICC sensor integrated unit

SPECIAL REPAIR REQUIREMENT

A
B
C
D
E
F
G
H
I
J
K
L
M
N
P

CCS

1. LASER BEAM AIMING ADJUSTMENT OF ICC SENSOR INTEGRATED UNIT

Adjust the laser beam aiming of the ICC sensor integrated unit. Refer to [CCS-6. "LASER BEAM AIMING ADJUSTMENT : Description"](#).

>> GO TO 2.

2. CHECK ICC SYSTEM

1. Erase the "Self Diagnostic Result", and then perform "All DTC Reading" again after performing the action test. (Refer to [CCS-11. "ACTION TEST : Description"](#) for action test.)
2. Check that the ICC system is normal.

>> WORK END

U1000 CAN COMM CIRCUIT

< DTC/CIRCUIT DIAGNOSIS >

[ICC]

U1000 CAN COMM CIRCUIT

Description

INFOID:000000005622625

CAN COMMUNICATION

CAN (Controller Area Network) is a serial communication line for real time applications. It is an on-vehicle multiplex communication line with high data communication speed and excellent error detection ability. Modern vehicle is equipped with many electronic control units, and each control unit shares information and links with other control units during operation (not independent). In CAN communication, control units are connected with 2 communication lines (CAN-H, CAN-L) allowing a high rate of information transmission with less wiring. Each control unit transmits/receives data but selectively reads the required data only.

CAN communication signal chart. Refer to [LAN-25. "CAN Communication Signal Chart"](#).

DTC Logic

INFOID:000000005622626

DTC DETECTION LOGIC

DTC (On board display)	Trouble diagnosis name	DTC detecting condition	Possible causes
U1000 (100)	CAN COMM CIRCUIT	If ICC sensor integrated unit is not transmitting or receiving CAN communication signal for 2 seconds or more	CAN communication system

NOTE:

If "U1000" is detected, first diagnose the CAN communication system.

Diagnosis Procedure

INFOID:000000005622627

1. PERFORM THE SELF-DIAGNOSIS

1. Turn the ignition switch ON.
2. Turn the MAIN switch of ICC system ON, and then wait for 2 seconds or more.
3. Perform "All DTC Reading" with CONSULT-III.
4. Check if the "U1000" is detected as the current malfunction in "Self Diagnostic Result" of "ICC".

Is "U1000" detected as the current malfunction?

- YES >> Refer to [LAN-16. "Trouble Diagnosis Flow Chart"](#).
NO >> Refer to [GI-37. "Intermittent Incident"](#).

Special Repair Requirement

INFOID:000000005622628

DESCRIPTION

Perform the action test after adjusting the laser beam aiming of ICC sensor integrated unit when the following operation is performed.

- Removal and installation of ICC sensor integrated unit
- Replacement of ICC sensor integrated unit

SPECIAL REPAIR REQUIREMENT

1. LASER BEAM AIMING ADJUSTMENT OF ICC SENSOR INTEGRATED UNIT

Adjust the laser beam aiming of the ICC sensor integrated unit. Refer to [CCS-6. "LASER BEAM AIMING ADJUSTMENT : Description"](#).

>> GO TO 2.

2. CHECK ICC SYSTEM

1. Erase the "Self Diagnostic Result", and then perform "All DTC Reading" again after performing the action test. (Refer to [CCS-11. "ACTION TEST : Description"](#) for action test.)
2. Check that the ICC system is normal.

A
B
C
D
E
F
G
H
I
J
K
L
M
N
P

CCS

U1000 CAN COMM CIRCUIT

< DTC/CIRCUIT DIAGNOSIS >

[ICC]

>> WORK END

U1010 CONTROL UNIT (CAN)

< DTC/CIRCUIT DIAGNOSIS >

[ICC]

U1010 CONTROL UNIT (CAN)

Description

INFOID:000000005622629

CAN controller controls the communication of CAN communication signal and the error detection.

DTC Logic

INFOID:000000005622630

DTC DETECTION LOGIC

DTC (On board display)	Trouble diagnosis name	DTC detecting condition	Possible causes
U1010 (110)	CONTROL UNIT (CAN)	If ICC sensor integrated unit detects malfunction by CAN controller initial diagnosis	ICC sensor integrated unit

Diagnosis Procedure

INFOID:000000005622631

1.PERFORM DTC CONFIRMATION PROCEDURE

1. Turn the MAIN switch of ICC system ON.
2. Perform "All DTC Reading" with CONSULT-III.
3. Check if the "U1010" is detected as the current malfunction in "Self Diagnostic Result" of "ICC".

Is "U1010" detected as the current malfunction?

- YES >> Replace the ICC sensor integrated unit. Refer to [CCS-135, "Exploded View"](#).
NO >> INSPECTION END

Special Repair Requirement

INFOID:000000005622632

DESCRIPTION

Perform the action test after adjusting the laser beam aiming of ICC sensor integrated unit when the following operation is performed.

- Removal and installation of ICC sensor integrated unit
- Replacement of ICC sensor integrated unit

SPECIAL REPAIR REQUIREMENT

1.LASER BEAM AIMING ADJUSTMENT OF ICC SENSOR INTEGRATED UNIT

Adjust the laser beam aiming of the ICC sensor integrated unit. Refer to [CCS-6, "LASER BEAM AIMING ADJUSTMENT : Description"](#).

>> GO TO 2.

2.CHECK ICC SYSTEM

1. Erase the "Self Diagnostic Result", and then perform "All DTC Reading" again after performing the action test. (Refer to [CCS-11, "ACTION TEST : Description"](#) for action test.)
2. Check that the ICC system is normal.

>> WORK END

A
B
C
D
E
F
G
H
I
J
K
L
M
N
P

CCS

POWER SUPPLY AND GROUND CIRCUIT

< DTC/CIRCUIT DIAGNOSIS >

[ICC]

POWER SUPPLY AND GROUND CIRCUIT

Diagnosis Procedure

INFOID:000000005622633

1. CHECK FUSES

Check if any of the following fuses are blown:

Signal name	Fuse No.
Ignition power supply	45

Is the inspection result normal?

YES >> GO TO 2.

NO >> Replace the blown fuse after repairing the affected circuit if a fuse is blown.

2. CHECK ICC SENSOR INTEGRATED UNIT POWER SUPPLY CIRCUIT

1. Turn the ignition switch OFF.
2. Disconnect the ICC sensor integrated unit connector.
3. Turn the ignition switch ON.
4. Check voltage between ICC sensor integrated unit harness connector and ground.

Terminal		Voltage (Approx.)
(+)	(-)	
ICC sensor integrated unit		Battery voltage
Connector	Terminal	
E67	1	

Is the inspection result normal?

YES >> GO TO 3.

NO >> Repair the ICC sensor integrated unit power supply circuit.

3. CHECK ICC SENSOR INTEGRATED UNIT GROUND CIRCUIT

1. Turn the ignition switch OFF.
2. Check for continuity between ICC sensor integrated unit harness connector and ground.

ICC sensor integrated unit		Ground	Continuity
Connector	Terminal		
E67	4		Existed

Is the inspection result normal?

YES >> INSPECTION END

NO >> Repair the ICC sensor integrated unit ground circuit.

PARK/NEUTRAL POSITION SWITCH CIRCUIT

< DTC/CIRCUIT DIAGNOSIS >

[ICC]

PARK/NEUTRAL POSITION SWITCH CIRCUIT

Description

INFOID:000000005622634

Park/neutral position switch signals is input to ECM. The signals are transmitted from ECM to ICC sensor integrated unit via CAN communication.

ICC sensor integrated unit performs the following controls via park/neutral position switch.

- Rejects any attempt to set ICC system when shift knob is set at neutral position.
- Cancels ICC system when shift knob is shifted to neutral position.

Component Function Check

INFOID:000000005622635

1.CHECK OPERATION OF PARK/NEUTRAL POSITION SWITCH

Check that "NP SW SIG" operate normally in "DATA MONITOR" of "ICC" with CONSULT-III.

"NP SW SIG"

Shift knob at neutral : On

Shift knob at a position other than neutral : Off

Is the inspection result normal?

YES >> The park/neutral position switch circuit is normal.

NO >> Refer to [CCS-103, "Diagnosis Procedure"](#).

Diagnosis Procedure

INFOID:000000005622636

1.CHECK FUSES

Check if any of the following fuses are blown:

Signal name	Fuse No.
Ignition power supply	43

Is the inspection result normal?

YES >> GO TO 2.

NO >> Replace the blown fuse after repairing the affected circuit if a fuse is blown.

2.CHECK PARK/NEUTRAL POSITION SWITCH POWER SUPPLY CIRCUIT

1. Turn ignition switch OFF.
2. Disconnect the park/neutral position switch connector.
3. Turn ignition switch ON.
4. Check voltage between park/neutral position switch harness connector and ground.

Terminal		Voltage (Approx.)
(+)	(-)	
Park/neutral position switch		Ground
Connector	Terminal	
F55	2	
		Battery voltage

Is the inspection result normal?

YES >> GO TO 3.

NO >> Repair the harnesses or connectors.

3.CHECK HARNESS BETWEEN PARK/NEUTRAL POSITION SWITCH AND ECM

1. Turn ignition switch OFF.
2. Disconnect the ECM connector.
3. Check for continuity between the park/neutral position switch harness connector and ECM harness connector.

PARK/NEUTRAL POSITION SWITCH CIRCUIT

[ICC]

< DTC/CIRCUIT DIAGNOSIS >

Park/neutral position switch		ECM		Continuity
Connector	Terminal	Connector	Terminal	
F55	1	M107	109	Existed

Is the inspection result normal?

- YES >> GO TO 4.
- NO >> Repair the harnesses or connectors.

4.CHECK PARK/NEUTRAL POSITION SWITCH

Check the park/neutral position switch. Refer to [CCS-104, "Component Inspection"](#).

Is the inspection result normal?

- YES >> GO TO 5.
- NO >> Replace the park/neutral position switch.

5.PERFORM SELF-DIAGNOSIS OF ECM

1. Connect connectors of park/neutral position switch and ECM.
2. Perform "All DTC Reading".
3. Check if any DTC is detected in "Self Diagnostic Result" of "ENGINE".

Is any DTC detected?

- YES >> Perform diagnosis on the detected DTC and repair or replace the malfunctioning parts. Refer to [EC-548, "DTC Index"](#).
- NO >> Replace the ICC sensor integrated unit. Refer to [CCS-135, "Exploded View"](#).

Component Inspection

INFOID:000000005622637

1.CHECK PARK/NEUTRAL POSITION SWITCH

Check for continuity between the park/neutral position switch terminals.

Terminals		Condition	Continuity
1	2	When shift knob is neutral position	Existed
		When shift knob is except neutral position	Not existed

Is the inspection result normal?

- YES >> INSPECTION END
- NO >> Replace park/neutral position switch.

ICC SENSOR INTEGRATED UNIT

< ECU DIAGNOSIS INFORMATION >

[ICC]

ECU DIAGNOSIS INFORMATION

ICC SENSOR INTEGRATED UNIT

Reference Value

INFOID:0000000005622638

VALUES ON THE DIAGNOSIS TOOL

Monitor item	Condition		Value/Status
MAIN SW	Ignition switch ON	When MAIN switch is pressed	On
		When MAIN switch is not pressed	Off
SET/COAST SW	Ignition switch ON	When SET/COAST switch is pressed	On
		When SET/COAST switch is not pressed	Off
CANCEL SW	Ignition switch ON	When CANCEL switch is pressed	On
		When CANCEL switch is not pressed	Off
RESUME/ACC SW	Ignition switch ON	When RESUME/ACCELERATE switch is pressed	On
		When RESUME/ACCELERATE switch is not pressed	Off
DISTANCE SW	Ignition switch ON	When DISTANCE switch is pressed	On
		When DISTANCE switch is not pressed	Off
CRUISE OPE	Drive the vehicle and operate the ICC system.	When ICC system is controlling	On
		When ICC system is not controlling	Off
BRAKE SW	Ignition switch ON	<ul style="list-style-type: none"> When brake pedal is depressed When clutch pedal is depressed (M/T models) 	Off
		When brake pedal and clutch pedal (M/T models) are not depressed	On
STOP LAMP SW	Ignition switch ON	When brake pedal is depressed	On
		When brake pedal is not depressed	Off
IDLE SW	Engine running	Idling	On
		Except idling (depress accelerator pedal)	Off
SET DISTANCE	<ul style="list-style-type: none"> Start the engine and turn the ICC system ON. Press the DISTANCE switch to change the vehicle-to-vehicle distance setting. 	When set to "long"	Long
		When set to "middle"	Mid
		When set to "short"	Short
CRUISE LAMP	Start the engine and press MAIN switch.	ICC system ON (MAIN switch indicator ON)	On
		ICC system OFF (MAIN switch indicator OFF)	Off
OWN VHCL	Start the engine and press MAIN switch.	ICC system ON (Own vehicle indicator ON)	On
		ICC system OFF (Own vehicle indicator OFF)	Off
VHCL AHEAD	Drive the vehicle and activate the vehicle-to-vehicle distance control mode.	When a vehicle ahead is detected (vehicle ahead detection indicator ON)	On
		When a vehicle ahead is not detected (vehicle ahead detection indicator OFF)	Off
ICC WARNING	Start the engine and press the MAIN switch.	When ICC system is malfunctioning (ICC system warning lamp ON)	On
		When ICC system is normal (ICC system warning lamp OFF)	Off

ICC SENSOR INTEGRATED UNIT

< ECU DIAGNOSIS INFORMATION >

[ICC]

Monitor item	Condition		Value/Status
VHCL SPEED SE	While driving		Value of vehicle speed signal (wheel speed)
SET VHCL SPD	While driving	When vehicle speed is set	Displays the set vehicle speed.
BUZZER O/P	Engine running	When the buzzer output signal is output	On
		When the buzzer output signal is not output	Off
THRTL SENSOR	NOTE: The item is indicated, but not monitored		0.0
ENGINE RPM	Engine running		Equivalent to tachometer reading
WIPER SW	Ignition switch ON	Wiper not operating	Off
		Wiper LO operation	Low
		Wiper HI operation	High
YAW RATE	NOTE: The item is indicated, but not monitored		0.0
STP LMP DRIVE	Drive the vehicle and activate the vehicle-to-vehicle distance control mode.	When ICC brake hold relay is activated	On
		When the ICC brake hold relay is not activated	Off
D RANGE SW	Engine running	When the selector lever is in "D", "DS" position or manual mode (A/T models)	On
		When the selector lever is in any position other than "D", "DS" or manual mode (A/T models)	Off
NP RANGE SW	Engine running	When the selector lever is in "N", "P" position (A/T models)	On
		When the selector lever is in any position other than "N", "P" (A/T models)	Off
PKB SW	NOTE: The item is indicated, but not monitored		Off
PWR SUP MONI	Engine running		Power supply voltage value of ICC sensor integrated unit
VHCL SPD AT	While driving		Value of A/T vehicle speed sensor signal
THRTL OPENING	Engine running	Depress accelerator pedal	Displays the throttle position.
GEAR	While driving		Displays the shift position.
CLUTCH SW SIG	Ignition switch ON	<ul style="list-style-type: none"> • When clutch pedal is depressed (M/T models) • When brake pedal is depressed (M/T models) 	On
		When clutch pedal and brake pedal are not depressed (M/T models)	Off
NP SW SIG	Ignition switch ON	When neutral position is selected (M/T models)	On
		When any position other than neutral is selected (M/T models)	Off
MODE SIG	Start the engine and press MAIN switch	When ICC system is deactivated	Off
		When vehicle-to-vehicle distance control mode is activated	ICC
		When conventional (fixed speed) cruise control mode is activated	ASCD

ICC SENSOR INTEGRATED UNIT

< ECU DIAGNOSIS INFORMATION >

[ICC]

Monitor item	Condition	Value/Status
SET DISP IND	• Start the engine and activate the conventional (fixed speed) cruise control mode • Press SET/COAST switch	SET switch indicator ON On
		SET switch indicator OFF Off
DISTANCE	Drive the vehicle and activate the vehicle-to-vehicle distance control mode.	When a vehicle ahead is detected Displays the distance from the preceding vehicle.
		When a vehicle ahead is not detected 0.0
RELATIVE SPD	Drive the vehicle and activate the vehicle-to-vehicle distance control mode.	When a vehicle ahead is detected Displays the relative speed.
		When a vehicle ahead is not detected 0.0

TERMINAL LAYOUT

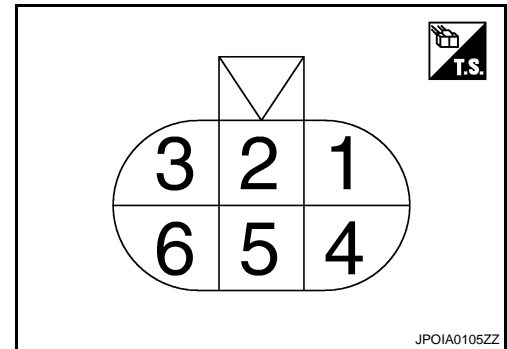

PHYSICAL VALUES

Terminal No. (Wire color)		Description		Condition	Value (Approx.)
+	-	Signal name	Input/ Output		
1 (R)	Ground	Ignition power supply	Input	Ignition switch ON	Battery voltage
2 (V)		ICC brake hold relay drive signal	Output	Ignition switch ON	0 V
3 (L)		CAN-H	Input/ Output	—	—
4 (B)		Ground	—	Ignition switch ON	0 V
6 (P)		CAN-L	Input/ Output	—	—
				At "STOP LAMP" test of "Active test"	12 V

A
B
C
D
E
F
G
H
I
J
K
L
M
N
P

CCS

ICC SENSOR INTEGRATED UNIT

< ECU DIAGNOSIS INFORMATION >

[ICC]

Wiring Diagram - INTELLIGENT CRUISE CONTROL -

INFOID:000000005622639

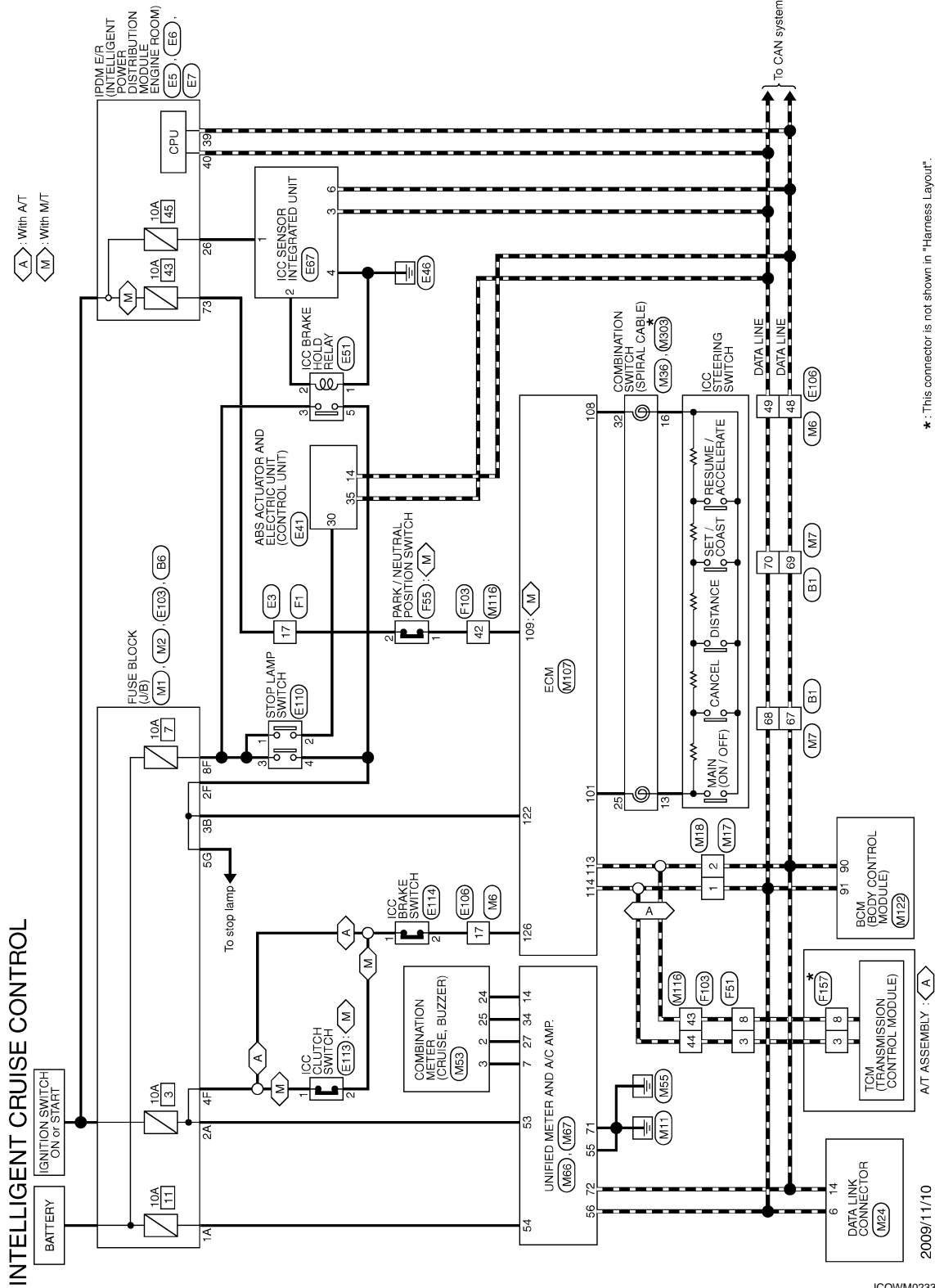

ICC SENSOR INTEGRATED UNIT

< ECU DIAGNOSIS INFORMATION >

[ICC]

INTELLIGENT CRUISE CONTROL

Connector No.	B1
Connector Name	WIRE TO WIRE
Connector Type	TH80PW-CS16-TM4



Terminal No.	Color of Wire	Signal Name [Specification]
1	W	
2	L	
3	R	
4	V	
5	W	
6	B	
7	G	
8	B	
9	G	
10	BR	
11	SHIELD	
12	Y	
13	Y	
14	L	
15	R	
16	W	
17	BR	
20	G	
21	SB	
22	GR	
23	W	
24	SB	
25	BR	
26	LG	
27	Y	
28	R	
29	V	
31	SHIELD	
32	G	
33	R	
34	BG	
35	GR	
36	BR	
37	P	- [With climate controlled seat]
37	Y	- [Without climate controlled seat]
38	V	- [With climate controlled seat]
38	GR	- [Without climate controlled seat]
40	SHIELD	
41	L	
42	P	
43	SHIELD	

44	SB	
45	V	- [With BOSE system]
46	W	- [Without BOSE system]
47	SB	
48	LG	
49	LG	- [With BOSE system]
49	Y	- [Without BOSE system]
50	SB	
50	LG	- [With BOSE system]
50	LG	- [Without BOSE system]
51	SB	
52	G	
53	LG	
54	BR	
55	Y	
56	W	
57	V	
60	R	
61	BG	
62	B	
63	L	
64	P	
65	B	
66	SB	
68	L	
68	P	
69	P	
70	L	
80	G	
81	V	
82	R	
83	BR	
84	G	
85	L	
86	Y	
87	GR	
91	R	
93	BG	
94	P	
95	GR	
96	GR	
97	SB	
99	Y/B	
100	Y/B	

Connector No.	B6
Connector Name	FUSE BLOCK (L/R)
Connector Type	MS12FBR-CS



Terminal No.	Color of Wire	Signal Name [Specification]
4G	R	
5G	LG	
6G	G	
10G	P	
11G	G	
12G	Y	

Connector No.	E3
Connector Name	WIRE TO WIRE
Connector Type	SAA38MB-RS3-SHZ8

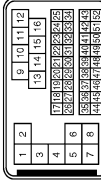

Terminal No.	Color of Wire	Signal Name [Specification]
1	L/Y	
2	SHIELD	
3	L/B	
4	SHIELD	
5	BR	
7	G	
8	W	
9	W	
10	Y	
11	P	
12	SB	
13	BR	
14	G	
15	R	
16	LG	
17	P	

18	Y	
19	BG	
20	B	
21	SB	
22	W	
23	L	
24	G	
25	V	
27	GR	
28	V	
29	P	
30	R	
31	BR	
32	Y	
33	G	
34	BG	
37	SHIELD	
38	L	
39	P	
40	R	
41	W	
42	LG	
43	G	
46	SHIELD	
47	W	
48	BR	
49	G	
50	B	
51	SB	
52	R	

A
B
C
D
E
F
G
H
I
J
K
L
M
N
P

CCS

ICC SENSOR INTEGRATED UNIT

< ECU DIAGNOSIS INFORMATION >

[ICC]

INTELLIGENT CRUISE CONTROL

Connector No.	E5
Connector Name	SMVLE INTELLIGENT POWER DISTRIBUTION MODULE (ENGINE ROOM)
Connector Type	TH02PW-CS12-M4-TV

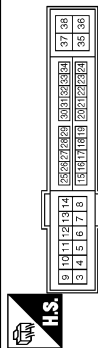

Terminal No.	Color of Wire	Signal Name [Specification]
4	V	-
5	L	-
7	R	-
11	BR	-
12	B/W	-
13	Y	-
16	LG	-
18	W	-
25	G	-
26	R	-
27	BG	-
28	L	-
30	GR	-
32	V	-
33	P	-
36	G	-

Connector No.	E6
Connector Name	SMVLE INTELLIGENT POWER DISTRIBUTION MODULE (ENGINE ROOM)
Connector Type	TH08BY-NH

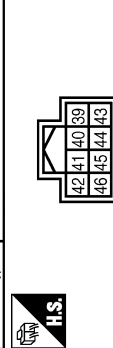

Terminal No.	Color of Wire	Signal Name [Specification]
39	P	-
40	L	-
41	B/W	-
42	Y	-
43	SB	-
44	LG	-

45	G	-
46	W	-

Connector No.	E7
Connector Name	SMVLE INTELLIGENT POWER DISTRIBUTION MODULE (ENGINE ROOM)
Connector Type	TH20PW-CS12-M4

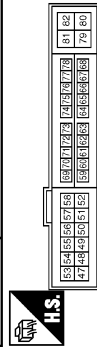

Terminal No.	Color of Wire	Signal Name [Specification]
48	BR	-
49	BG	-
51	Y	-
53	W	-
54	P	-
55	SB	-
56	LG	-
57	G	-
58	GR	-
69	BR	-
70	BG	-
73	P	-
74	G	-
75	SB	-
76	Y	-
77	R	-
80	W	-

Connector No.	E41
Connector Name	ABS ACTUATOR AND ELECTRO LIMIT (CONTROL UNIT)
Connector Type	BAA2FB-AH24-LH

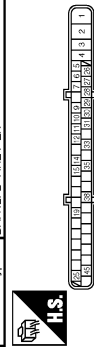

Terminal No.	Color of Wire	Signal Name [Specification]
1	B	GND

Connector No.	E67
Connector Name	ICC SENSOR INTEGRATED UNIT
Connector Type	RS06FB-PR



Terminal No.	Color of Wire	Signal Name [Specification]
1	R	IGNITION
2	V	BRAKE HOLD RLY DRIVE SIGNAL
3	L	CAN-H
4	B	GND
6	P	CAN-L

Connector No.	E03
Connector Name	FUSE BLOCK (J/B)
Connector Type	NS16FW-CS

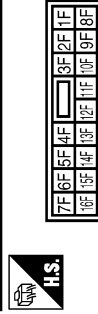

Terminal No.	Color of Wire	Signal Name [Specification]
1F	SB	-
2F	V	-
4F	G	-
8F	BG	-
9F	L	-
9F	R	-

Terminal No.	Color of Wire	Signal Name [Specification]
2	L	UBWR
3	R	UBVR
4	B	GND
5	V	DS EL
6	BG	DP RL
7	BR	DP RR
9	B	DP FR
10	W	DS FR
11	V	DIAG-K
14	P	CAN-L
23	Y	BUS-L
26	LG	DP FL
27	GR	DS RL
28	G	UZ
29	P	DS RR
30	SB	BLS
31	R	VDC OFF SWITCH
35	L	CAN-H
45	B	BUS-H

Connector No.	E51
Connector Name	ICC BRAKE HOLD RELAY
Connector Type	MS02FL-M2-LC

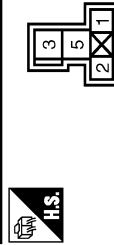

Terminal No.	Color of Wire	Signal Name [Specification]
1	B	-
2	V	-
3	R	-
5	P	-

ICC SENSOR INTEGRATED UNIT

< ECU DIAGNOSIS INFORMATION >

[ICC]

INTELLIGENT CRUISE CONTROL

Connector No.	E106
Connector Name	WIRE TO WIRE
Connector Type	TH80FW-CS16-TM4



Terminal No.	Color of Wire	Signal Name [Specification]
1	GR	
3	BG	
4	B/W	
5	G	
6	BG	
7	LG	
8	G	
10	W	
11	V	
12	R	
13	L	
14	GR	
15	P	
16	W	
17	V	
18	BG	
19	GR	
20	LG	
30	R	
31	L	
32	BG	
33	P	
34	V	
35	BR	
36	W	
37	Y	
38	R	
39	B	
40	G	
41	W	
42	LG	
43	SB	
44	GR	
45	BG	
46	LG	
47	V	
48	P	
48	L	

59	B	
66	LG	
67	SB	
68	R	
69	W	
70	G	
80	W	
81	P	
82	G	
83	V	
84	L	
85	BG	
86	LG	
87	Y	
88	GR	
89	W	
90	W	
91	G	
92	B	
93	GR	
94	L	
95	Y	
97	BR	
98	SHIELD	
99	L	
100	P	

Connector No.	E110
Connector Name	STOP LAMP SWITCH
Connector Type	M04FW-LG



Terminal No.	Color of Wire	Signal Name [Specification]
1	L	
2	V	
3	L	- [With ICC]
3	Y	- [Without ICC]
4	SB	- [With ICC]
4	W	- [Without ICC]

Connector No.	E113
Connector Name	ICC CLUTCH SWITCH
Connector Type	S02FL



Terminal No.	Color of Wire	Signal Name [Specification]
1	G	
2	R	

Connector No.	E114
Connector Name	ICC BRAKE SWITCH
Connector Type	S02FL



Terminal No.	Color of Wire	Signal Name [Specification]
1	G	
1	R	- [With A.T.]
2	V	- [With M.T.]

Connector No.	F1
Connector Name	WIRE TO WIRE
Connector Type	SAA38FB-RSS-SH28

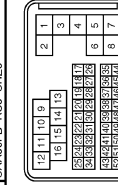

Terminal No.	Color of Wire	Signal Name [Specification]
1	L/Y	

2	SHIELD	
3	L/B	
4	SHIELD	
5	BR	
7	G	
8	W	
9	W	
10	G	
11	R	
12	P	
13	L	
14	LG	
15	R	
16	Y	
17	W	
18	LG	
19	P	
20	O	
21	BR	
22	G	
23	Y	
24	LG	
25	V	
27	GR	
28	BR	
29	L	
30	R	
31	P	
32	W	
33	SB	
34	O	
37	B	
38	W	
39	Y	
40	G	
41	B	
42	GR	
43	R	
46	SHIELD	
47	W/L	
48	LG	
49	O/L	
50	L/Y	
51	W	
52	L/G	

A
B
C
D
E
F
G
H
I
J
K
L
M
N
P



ICC SENSOR INTEGRATED UNIT

< ECU DIAGNOSIS INFORMATION >

[ICC]

INTELLIGENT CRUISE CONTROL

Connector No.	F51
Connector Name	A/T ASSEMBLY
Connector Type	RK10FG-DCY

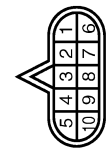

Terminal No.	Color of Wire	Signal Name [Specification]
1	Y	-
2	R	-
3	L	-
4	V	-
5	B	-
6	Y	-
7	R	-
8	P	-
9	GR	-
10	B	-

Connector No.	F55
Connector Name	PARK / NEUTRAL POSITION SWITCH
Connector Type	RK02FB



Terminal No.	Color of Wire	Signal Name [Specification]
1	BR	-
2	W	-

Connector No.	F103
Connector Name	WIRE TO WIRE
Connector Type	TK38FW-NS10

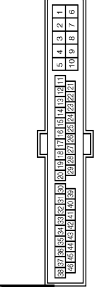

Terminal No.	Color of Wire	Signal Name [Specification]
2	G	-
3	W	-
4	R	-
5	B	-
6	Y	-
7	GR	-
8	O	-
9	Y	-
10	B	-
11	GR	-
12	Y	-
13	B	-
14	LG	-
15	R	-
16	R	-
17	O	-
18	BR	-
19	P	-
20	L	-
21	Y	-
22	L	-
23	Y	-
24	Y	-
25	Y	-
26	Y	-
27	Y	-
28	Y	-
29	Y	-
30	R	-
31	R	-
32	O	-
33	BR	-
34	P	-
35	L	-
36	L	-
37	Y	-
38	Y	-
39	V	-
40	V	-

Connector No.	F157
Connector Name	TCM (TRANSMISSION CONTROL MODULE)
Connector Type	SP10FG

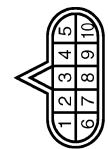

Terminal No.	Color of Wire	Signal Name [Specification]
1	W	VIGN
2	B	BATT
3	R	CAN-H
4	O	K-LINE

5	G	GND
6	GR	VIGN
7	L	REV LAMP RLY
8	BR	CAN-L
9	Y	STARTER RLY
10	W/B	GND

Connector No.	M1
Connector Name	FUSE BLOCK (J/B)
Connector Type	NS08FW-M2

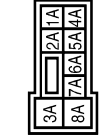

Terminal No.	Color of Wire	Signal Name [Specification]
1A	V	-
2A	G	-
3A	L	-
4A	L	-
5A	BR	-
6A	Y	-
7A	GR	-
8A	L	-

Connector No.	M2
Connector Name	FUSE BLOCK (J/B)
Connector Type	NS10FW-CS

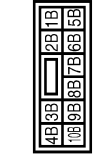

Terminal No.	Color of Wire	Signal Name [Specification]
1B	R	-
2B	R	-
3B	P	-
4B	G	-
5B	BG	-
6B	Y	-
7B	P	-

8B	R	-
9B	SB	-

ICC SENSOR INTEGRATED UNIT

< ECU DIAGNOSIS INFORMATION >

[ICC]

INTELLIGENT CRUISE CONTROL

Connector No.	M6
Connector Name	WIRE TO WIRE
Connector Type	TH80MW-CS (F-TM4)

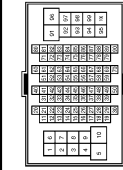

Terminal No.	Color of Wire	Signal Name [Specification]
1	BG	-
2	R	-
3	R	-
4	G	-
5	G	-
6	BR	-
7	BR	-
8	Y	-
9	W	-
10	W	-
11	GR	-
12	R	-
13	L	-
14	G	-
15	P	-
16	W	-
17	BR	-
18	V	-
19	BG	-
20	L	-
30	R	-
31	L	-
32	Y	-
33	GR	-
34	P	-
35	BR	-
36	BR	-
37	Y	-
38	LG	-
39	SB	-
40	G	-
41	W	-
42	LG	-
43	P	-
44	GR	- [With A/T] - [With M/T]
45	R	-
46	BG	-
47	L	-
48	P	-
49	P	-

49	L	-
59	B	-
66	Y	-
67	G	-
68	R	-
69	W	-
70	G	-
80	SB	-
81	R	-
82	V	-
83	W	-
84	L	-
85	BG	-
86	G	-
87	V	-
88	B	-
89	SB	-
90	G	-
91	W	-
92	B	-
93	G	-
94	L	-
95	BR	-
97	P	-
98	SHIELD	-
99	V	-
100	SB	-

Connector No.	M7
Connector Name	WIRE TO WIRE
Connector Type	TH80MW-CS (F-TM4)

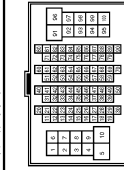

Terminal No.	Color of Wire	Signal Name [Specification]
1	BG	-
2	LG	-
3	G	-
4	V	-
5	L	-
6	B	-
9	L	-
10	BR	-
12	SHIELD	-

66	Y	-
67	P	-
68	L	-
69	P	-
70	L	-
80	G	-
81	LG	-
82	Y	-
83	BR	-
84	B	-
85	L	-
86	Y	-
87	GR	-
91	R	-
93	G	-
94	P	-
95	GR	-
96	Y	-
97	SB	-
99	Y	-
100	Y/B	-

Connector No.	M17
Connector Name	WIRE TO WIRE
Connector Type	TK02FW



Terminal No.	Color of Wire	Signal Name [Specification]
1	L	-
2	P	-

13	V	-
14	BR	-
15	GR	-
16	LG	-
17	L	-
20	BR	-
21	G	-
22	R	-
23	SB	-
24	B	-
25	W	-
26	Y	-
27	V	-
28	P	-
29	V	-
31	SHIELD	-
32	G	-
33	R	-
34	BG	-
35	GR	-
36	GR	-
37	P	-
37	L	- [With climate controlled seat] - [Without climate controlled seat]
38	V	-
38	GR	- [Without climate controlled seat]
40	SHIELD	-
41	L	-
42	P	-
43	SHIELD	-
44	Y	-
45	BR	-
46	SB	-
47	SB	-
48	LG	-
49	LG	-
49	SB	- [With BOSE system] - [Without BOSE system]
50	SB	- [With BOSE system] - [Without BOSE system]
51	R	-
52	V	-
53	P	-
54	BR	-
55	Y	- [With A/T] - [With M/T]
56	BG	-
57	V	-
60	LG	-
61	BG	-
62	B	-
63	V	-
64	SR	-
65	BR	-

A
B
C
D
E
F
G
H
I
J
K
L
M
N
P



ICC SENSOR INTEGRATED UNIT

< ECU DIAGNOSIS INFORMATION >

[ICC]

INTELLIGENT CRUISE CONTROL

Connector No.	M18
Connector Name	WIRE TO WIRE
Connector Type	TK02NW



Terminal No.	Color of Wire	Signal Name [Specification]
1	L	-
2	P	-

Connector No.	M24
Connector Name	DATA LINK CONNECTOR
Connector Type	BD16FW



Terminal No.	Color of Wire	Signal Name [Specification]
3	LG	-
4	B	-
5	BR	-
6	L	-
7	V	-
8	G	-
11	SB	-
14	P	-
16	R	-

Connector No.	M36
Connector Name	COMBINATION SWITCH (SPIRAL CABLE)
Connector Type	TK08FY-IV



Terminal No.	Color of Wire	Signal Name [Specification]
24	P	-
25	SB	-
26	BR	-
31	L	-
32	Y	-
33	B	-
34	LG	-

Connector No.	M53
Connector Name	COMBINATION METER
Connector Type	SAB40FW

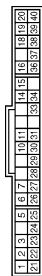

Terminal No.	Color of Wire	Signal Name [Specification]
1	V	BATTERY POWER SUPPLY
2	LG	COMMUNICATION SIGNAL (METER->AMP.)
3	GR	COMMUNICATION SIGNAL (AMP->METER)
5	B	GROUND
6	W	ALTERNATOR SIGNAL
7	LG	AIR BAG SIGNAL
10	R	SECURITY SIGNAL
15	B	GROUND
16	B	METER CONTROL SWITCH GROUND
18	GR	ILL GND
19	B	ILL GND
20	R	ILL
21	R	IGNITION SIGNAL
22	B	GROUND
24	SB	COMMUNICATION SIGNAL (LCD->AMP.)

25	B	COMMUNICATION SIGNAL (AMP->LCD)
26	R	VEHICLE SPEED SIGNAL (8-PULSE)
27	V	PARKING BRAKE SWITCH SIGNAL
28	SB	BRAKE FLUID LEVEL SWITCH SIGNAL
29	L	SEAT BELT BUCKLE SW SIGNAL (DRIVER SIDE)
30	G	SEAT BELT BUCKLE SWITCH SIGNAL (PASSENGER SIDE)
31	L	WASHER LEVEL SWITCH SIGNAL
33	R	ILLUMINATION CONTROL SIGNAL
36	LG	SELECT SWITCH SIGNAL
37	SB	ENTER SWITCH SIGNAL
38	L	TRIP A/B RESET SWITCH SIGNAL
39	P	ILLUMINATION CONTROL SWITCH (-)
40	BG	ILLUMINATION CONTROL SWITCH (+)

Connector No.	M66
Connector Name	UNIFIED METER AND A/C AMP.
Connector Type	TH40PW-RII



Terminal No.	Color of Wire	Signal Name [Specification]
4	G	STOP LAMP SWITCH
5	L	MANUAL MODE SHIFT UP SIGNAL
6	BG	PADDLE SHIFTER UP SIGNAL
7	GR	COMMUNICATION SIGNAL (AMP->METER)
8	L	VEHICLE SPEED (2-PULSE)
9	SB	SEAT BELT BUCKLE SWITCH SIGNAL (DRIVER SIDE)
10	W	MANUAL MODE SIGNAL
11	G	NON-MANUAL MODE SIGNAL
14	SB	COMMUNICATION SIGNAL (LCD->AMP.)
20	V	IGN ON / OFF SIGNAL
25	G	MANUAL MODE SHIFT DOWN SIGNAL
27	LG	PADDLE SHIFTER DOWN SIGNAL
28	R	VEHICLE SPEED (8-PULSE)
30	V	PARKING BRAKE SWITCH SIGNAL
34	B	COMMUNICATION SIGNAL (AMP->LCD)
38	P	BLOWER MOTOR CONTROL SIGNAL

Connector No.	M67
Connector Name	UNIFIED METER AND A/C AMP.
Connector Type	TH42FW-NH

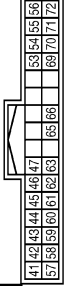

Terminal No.	Color of Wire	Signal Name [Specification]
41	BR	AGC POWER SUPPLY
42	BR	FUEL LEVEL SENSOR SIGNAL
43	R	INTAKE SENSOR SIGNAL
44	LG	IN-VEHICLE SENSOR SIGNAL
45	V	AMBIENT SENSOR SIGNAL
46	BG	SUNLOAD SENSOR SIGNAL
47	G	GAS SENSOR SIGNAL
53	W	IGNITION POWER SUPPLY
54	BG	BATTERY POWER SUPPLY
55	B	GROUND
56	L	CAN-H
57	LG	BRAKE FLUID LEVEL SWITCH SIGNAL
58	Y	FUEL LEVEL SENSOR SIGNAL GROUND
59	GR	INTAKE SENSOR GROUND
60	L	IN-VEHICLE SENSOR GROUND
61	R	AMBIENT SENSOR GROUND
62	SB	SUNLOAD SENSOR GROUND
63	L	ION CONTROL MODE OUTPUT SIGNAL
65	BG	ECV SIGNAL
69	L	A.C. LAN SIGNAL
70	R	EACH DOOR MOTOR POWER SUPPLY
71	GR	GROUND
72	P	CAN-E

ICC SENSOR INTEGRATED UNIT

< ECU DIAGNOSIS INFORMATION >

[ICC]

18	-	-	-
19	-	-	-
20	-	-	-

76	V	DRIVER DOOR ANT-
77	LG	DRIVER DOOR ANT+
78	V	ROOM ANT 1-
79	BR	ROOM ANT 1+
80	GR	NATS ANTRNNA AMP-
81	W	NATS ANTRNNA AMP+
82	R	IGN RELAY (P/B) CONT
83	Y	KEYLESS ENTRY RECEIVER COMM
87	Y	COMBI SW INPUT 5
88	BG	COMBI SW INPUT 3
89	BR	PUSH SW
90	P	CAN-L
91	L	CAN-H
92	LG	KEY SLOT ILL
93	V	ON IND
95	BG	AGG RELAY CONT
96	GR	A/T SHIFT SELECTOR POWER SUPPLY
97	L	S/L CONDITION 1
98	SB	S/L CONDITION 2
99	R	SHIFT P (N/A/T)
99	R	ASCD/ICC CLUTCH SW (N/A/T)
100	Y	PASSENGER DOOR REQUEST SW
101	P	DRIVER DOOR REQUEST SW
102	BG	BLOWER FAN MOTOR RELAY COIL
103	LG	KEYLESS ENTRY RECEIVER POWER SUPPLY
106	W	S/L UNIT POWER SUPPLY
107	LG	COMBI SW INPUT 1
108	R	COMBI SW INPUT 4
109	W	COMBI SW INPUT 2
110	G	HAZARD SW
111	Y	S/L UNIT COMM

Connector No.	M303
Connector Name	COMBINATION SWITCH (SPIRAL CABLE)
Connector Type	TK08FGY



Terminal No.	Color of Wire	Signal Name [Specification]
13	-	-
14	-	-
15	-	-
16	-	-
17	-	-

Connector No.	M116
Connector Name	WIRE TO WIRE
Connector Type	TK38MP-MS10



Terminal No.	Color of Wire	Signal Name [Specification]
2	W	-
3	BG	-
4	R	-
5	B	-
9	R	-
10	R	-
19	BG	-
20	Y	-
28	GR	-
29	LG	-
30	LG	-
31	W	-
41	BG	-
42	G	-
43	P	-
44	L	-
45	G	-
46	Y	-

Connector No.	M122
Connector Name	BCM (BODY CONTROL MODULE)
Connector Type	TH4GFE-NH



Terminal No.	Color of Wire	Signal Name [Specification]
72	R	ROOM ANT 2-
73	G	ROOM ANT 2+
74	SR	PASSENGER DOOR ANT-
75	BR	PASSENGER DOOR ANT+

INTELLIGENT CRUISE CONTROL

Connector No.	M107
Connector Name	ECM
Connector Type	RH24FGY-R28-R-LH-Z



Terminal No.	Color of Wire	Signal Name [Specification]
97	R	AFS 1
98	P	AFS 2
99	L	AVCC 1-APS 1
100	W	GND-A-APS 1
101	SB	ASCD SW
102	G	FTPRS
103	G	AVCC 2-APS 2
104	GR	GND-APS 2
105	L	PDPRESS
106	LG	TF
107	BR	AVCC-PDPRES
108	Y	GND ASCDSW
109	G	NEUT-H
110	BR	TACHO
112	R	GND-PDPRES
113	P	VEHCAN-LI
114	L	VEHCAN-HI
117	V	KLINE
121	LG	CDGV
122	P	BRAKE
123	B	GND
124	B	GND
125	R	VBR
126	BR	ENGSW
127	B	GND
128	B	GND

JCOWM0240GI

INFOID:000000005622640

Fail-Safe

If a malfunction occurs in the system, a chime sounds a beep, and ICC sensor integrated unit cancels the control. Then the ICC system warning lamp in the combination meter illuminates.

DTC Inspection Priority Chart

INFOID:000000005622641

If multiple DTCs are detected simultaneously, check them one by one depending on the following DTC inspection priority chart.

A
B
C
D
E
F
G
H
I
J
K
L
M
N
P



ICC SENSOR INTEGRATED UNIT

< ECU DIAGNOSIS INFORMATION >

[ICC]

Priority	Detected items (DTC)
1	<ul style="list-style-type: none"> • U1000: CAN COMM CIRCUIT • U1010: CONTROL UNIT (CAN)
2	<ul style="list-style-type: none"> • C1A01: POWER SUPPLY CIR • C1A02: POWER SUPPLY CIR 2 • C1A04: ABS/TCS/VDC CIRC • C1A05: BRAKE SW/STOP L SW • C1A06: OPERATION SW CIRC • C1A12: LASER BEAM OFFCNTR • C1A13: STOP LAMP RLY FIX • C1A14: ECM CIRCUIT • C1A16: RADAR STAIN • C1A18: LASER AIMING INCOMP • C1A21: UNIT HIGH TEMP • C1A24: NP RANGE • C1A26: ECD MODE MALF • C1A27: ECD PWR SUPPLY CIR • C1A33: CAN TRANSMISSION ERROR • C1A34: COMMAND ERROR • U0121: VDC CAN CIR2 • U0401: ECM CAN CIR1 • U0402: TCM CAN CIR1 • U0415: VDC CAN CIR1
3	<ul style="list-style-type: none"> • C1A03: VHCL SPEED SE CIRC
4	<ul style="list-style-type: none"> • C1A15: GEAR POSITION
5	<ul style="list-style-type: none"> • C1A00: CONTROL UNIT

DTC Index

INFOID:000000005622642

NOTE:

- The details of time display are as per the following.
- 0: The malfunctions that are detected now
CAN communication system (U1000, U1010)
- 1 - 39: It increases like 0 → 1 → 2 ... 38 → 39 after returning to the normal condition whenever the ignition switch OFF → ON. It returns to 0 when a malfunction is detected again in the process.
- If it is over 39, it is fixed to 39 until the self-diagnosis results are erased.
Other than CAN communication system (Other than U1000, U1010)
- 1 - 49: It increases like 0 → 1 → 2 ... 38 → 49 after returning to the normal condition whenever the ignition switch OFF → ON. It returns to 0 when a malfunction is detected again in the process.
- If it is over 49, it is fixed to 49 until the self-diagnosis results are erased.

×: Applicable

DTC		CONSULT-III display	ICC system warning lamp	Fail-safe function			Reference
CONSULT-III	On board display			Vehicle-to-vehicle distance control mode	Conventional (fixed speed) cruise control mode	Brake Assist (with Preview Function)	
C1A00	0	CONTROL UNIT	×	×	×	×	CCS-43
C1A01	1	POWER SUPPLY CIR	×	×	×	×	CCS-45
C1A02	2	POWER SUPPLY CIR 2	×	×	×	×	CCS-45
C1A03	3	VHCL SPEED SE CIRC	×	×	×	×	CCS-47
C1A04	4	ABS/TCS/VDC CIRC	×	×	×	×	CCS-50
C1A05	5	BRAKE SW/STOP L SW	×	×	×	×	CCS-52
C1A06	6	OPERATION SW CIRC	×	×	×		CCS-60
C1A12	12	LASER BEAM OFFCNTR	×	×		×	CCS-63
C1A13	13	STOP LAMP RLY FIX	×	×		×	CCS-64

ICC SENSOR INTEGRATED UNIT

< ECU DIAGNOSIS INFORMATION >

[ICC]

DTC		CONSULT-III display	ICC system warning lamp	Fail-safe function			Reference
CONSULT-III	On board display			Vehicle-to-vehicle distance control mode	Conventional (fixed speed) cruise control mode	Brake Assist (with Preview Function)	
C1A14	14	ECM CIRCUIT	×	×	×	×	CCS-70
C1A15	15	GEAR POSITION	×	×	×		CCS-72
C1A16	16	RADAR STAIN	×	×		×	CCS-75
C1A18	18	LASER AIMING INCOMP	×	×		×	CCS-77
C1A21	21	UNIT HIGH TEMP	×	×	×	×	CCS-79
C1A24	24	NP RANGE	×	×	×	×	CCS-81
C1A26	26	ECD MODE MALF	×	×	×	×	CCS-83
C1A27	27	ECD PWR SUPPLY CIR	×	×	×	×	CCS-85
C1A33	33	CAN TRANSMISSION ERROR	×	×	×	×	CCS-87
C1A34	34	COMMAND ERROR	×	×	×	×	CCS-89
NO DTC IS DETECTED. FURTHER TESTING MAY BE REQUIRED	55	NO DTC IS DETECTED. FURTHER TESTING MAY BE REQUIRED.	—	—	—	—	—
U0121	127	VDC CAN CIR2	×	×	×	×	CCS-91
U0401	120	ECM CAN CIR1	×	×	×	×	CCS-93
U0402	122	TCM CAN CIR1	×	×	×	×	CCS-95
U0415	126	VDC CAN CIR1	×	×	×	×	CCS-97
U1000	100	CAN COMM CIRCUIT	×	×	×	×	CCS-99
U1010	110	CONTROL UNIT (CAN)	×	×	×	×	CCS-101

A
B
C
D
E
F
G
H
I
J
K
L
M
N
P

CCS

INTELLIGENT CRUISE CONTROL SYSTEM SYMPTOMS

< SYMPTOM DIAGNOSIS >

[ICC]

SYMPTOM DIAGNOSIS

INTELLIGENT CRUISE CONTROL SYSTEM SYMPTOMS

Symptom Table

INFOID:000000005622643

	Symptoms	Reference page
Operation	MAIN switch does not turn ON.	Refer to CCS-119, "Description" .
	MAIN switch does not turn OFF.	
	ICC system cannot be set (MAIN switch turns ON/OFF)	Refer to CCS-120, "Description" .
	CANCEL switch does not function.	Refer to CCS-122, "Description" .
	Resume does not function.	
	Set speed does not increase.	
	Set distance to a vehicle ahead cannot be changed.	
ICC is not canceled when the A/T selector lever is "N" position.	Refer to CCS-123, "Description" .	
Display/Chime	ICC system display not appear.	Refer to MWI-33, "Diagnosis Description" .
	Chime does not sound.	Refer to CCS-124, "Description" .
Control	Driving force is hunting.	Refer to CCS-126, "Description" .
Function to detect a vehicle ahead	System frequently cannot detect a vehicle ahead.	Refer to CCS-127, "Description" .
	Distance to detect a vehicle ahead is short.	
	System misidentifies a vehicle even though there is no vehicle ahead.	<ul style="list-style-type: none"> • Adjust laser beam aiming: Refer to CCS-6, "LASER BEAM AIMING ADJUSTMENT : Description". • Perform ICC system action test. Refer to CCS-11, "ACTION TEST : Description".
	System misidentifies a vehicle in the next lane.	
	System does not detect a vehicle at all.	Refer to CCS-128, "Description" .

MAIN SWITCH DOES NOT TURN ON, MAIN SWITCH DOES NOT TURN OFF

< SYMPTOM DIAGNOSIS >

[ICC]

MAIN SWITCH DOES NOT TURN ON, MAIN SWITCH DOES NOT TURN OFF

Description

INFOID:000000005622644

MAIN switch does not turn ON

- ICC system display does not appear even when MAIN switch is pressed.

MAIN switch does not turn OFF

- When ICC system display is ON, display does not turn OFF even if MAIN switch is pressed.

NOTE:

When ICC system warning lamp illuminates, perform the self-diagnosis of ICC system, and then repair or replace the malfunctioning parts.

Diagnosis Procedure

INFOID:000000005622645

1.MAIN SWITCH INSPECTION

1. Start the engine.
2. Check that "MAIN SW" and "CRUISE LAMP" operate normally in "DATA MONITOR" of "ICC" with CONSULT-III.

Is the inspection result normal?

- YES >> GO TO 2.
- NO >> GO TO 4.

2.CHECK UNIFIED METER AND A/C AMP.

Check that "CRUISE IND" operates normally in "DATA MONITOR" of "METER/M&A".

Is the inspection result normal?

- YES >> GO TO 3.
- NO >> GO TO 4.

3.PERFORM SELF-DIAGNOSIS OF UNIFIED METER AND A/C AMP.

1. Perform "Self Diagnostic Result" of "METER/M&A".
2. Check if DTC is detected. Refer to [MWI-102, "DTC Index"](#).

Is any DTC detected?

- YES >> Repair or replace malfunctioning parts.
- NO >> GO TO 4.

4.PERFORM SELF-DIAGNOSIS RESULTS OF ICC SYSTEM

1. Perform "All DTC Reading".
2. Check if the "U1000" is detected in self-diagnosis results of "ICC".

Is "U1000" detected?

- YES >> GO TO 5.
- NO >> GO TO 6.

5.CAN COMMUNICATIONS INSPECTION

Check the CAN communication and repair or replace malfunctioning parts. Refer to [CCS-99, "DTC Logic"](#).

>> INSPECTION END

6.CHECK ICC STEERING SWITCH

Check the ICC steering switch. Refer to [CCS-60, "Diagnosis Procedure"](#).

>> INSPECTION END

A
B
C
D
E
F
G
H
I
J
K
L
M
N
P

CCS

ICC SYSTEM CANNOT BE SET (MAIN SWITCH TURNS ON/OFF)

< SYMPTOM DIAGNOSIS >

[ICC]

ICC SYSTEM CANNOT BE SET (MAIN SWITCH TURNS ON/OFF)

Description

INFOID:000000005622646

The MAIN switch can be turned ON/OFF, but the ICC system cannot be set even if the SET/COAST switch is pressed.

NOTE:

The system cannot be set in the following case.

- When the vehicle speed is not in range of approximately 40 km/h (25 MPH) to 144 km/h (90 MPH).
- When the selector lever is not in the "D", "DS" position or manual mode. (A/T models)
- When the shift knob is set at the neutral position. (M/T models)
- When the front wipers are operating at LO or HI.
(If the vehicle is equipped with a rain sensing auto-wiper, the system may cancel when the wipers are set to INT)
- When the brake pedal is depressed.
- When the clutch pedal is depressed. (M/T models)
- When driving into a strong light (i.e., sunlight).
- When the VDC is turned OFF.
- When ABS or VDC (including the TCS) operates.
- When a wheel slips.

Diagnosis Procedure

INFOID:000000005622647

1. CHECK CAUSE OF AUTOMATIC CANCELLATION

Check if there is the cancellation cause in the "CAUSE OF AUTO-CANCEL" on "WORK SUPPORT" of "ICC" with CONSULT-III.

Is it displayed?

Not displayed >> GO TO 2.

"OPE SW VOLT CIRC" >> Refer to [CCS-60, "DTC Logic"](#).

"VHCL SPD UNMATCH" >> Refer to [CCS-47, "DTC Logic"](#).

"IGN LOW VOLT" >> Refer to [CCS-45, "DTC Logic"](#).

"ECM CIRCUIT" >> Refer to [CCS-70, "DTC Logic"](#).

"CAN COMM ERROR" >> Refer to [CCS-99, "DTC Logic"](#).

"ABS/TCS/VDC CIRC" >> Refer to [CCS-50, "DTC Logic"](#).

"ECD CIRCUIT" >> Refer to [CCS-83, "DTC Logic"](#).

2. PERFORM THE SELF-DIAGNOSIS

1. Perform "All DTC Reading".
2. Check if any DTC is detected in "Self Diagnostic Result" of "ICC". Refer to [CCS-116, "DTC Index"](#).

Is any DTC detected?

YES >> GO TO 3.

NO >> GO TO 4.

3. REPAIR OR REPLACE MALFUNCTIONING PARTS

Repair or replace malfunctioning parts identified by the self-diagnosis result.

>> GO TO 6.

4. CHECK EACH SWITCH AND VEHICLE SPEED SIGNAL

1. Start the engine.
2. Check that the following items operate normally in "DATA MONITOR" of "ICC".
 - "VHCL SPEED SE"
 - "D RANGE SW"
 - "SET/COAST SW"
 - "BRAKE SW"
 - "NP SW SIG"
 - "CLUTCH SW SIG"
 - "WIPER SW"

Is there a malfunctioning item?

ICC SYSTEM CANNOT BE SET (MAIN SWITCH TURNS ON/OFF)

< SYMPTOM DIAGNOSIS >

[ICC]

All items are normal>>GO TO 5.

“VHCL SPEED SE”>>Refer to [CCS-47, "DTC Logic"](#).

“D RANGE SW”>>Refer to [CCS-123, "Diagnosis Procedure"](#).

“SET/COAST SW”>>Refer to [CCS-60, "DTC Logic"](#).

“BRAKE SW”>>Refer to [CCS-52, "DTC Logic"](#).

“CLUTCH SW SIG”>>Refer to [CCS-52, "DTC Logic"](#).

“NP SW SIG”>>Refer to [CCS-104, "Component Inspection"](#).

“WIPER SW” (When the front wiper operation is normal)>>GO TO 5.

“WIPER SW” (When the front wiper operation is malfunctioning)>>Performs the diagnosis of the front wiper.

Refer to [WW-89, "WITH RAIN SENSOR : Symptom Table"](#).

5.REPLACE ICC SENSOR INTEGRATED UNIT

1. Replace the ICC sensor integrated unit. Refer to [CCS-135, "Exploded View"](#).

2. Perform the laser beam aiming. Refer to [CCS-6, "LASER BEAM AIMING ADJUSTMENT : Description"](#).

>> GO TO 6.

6.CHECK ICC SYSTEM

1. Erase the self-diagnosis results, and then perform “All DTC Reading” again after performing the action test. (Refer to [CCS-11, "ACTION TEST : Description"](#) for action test.)

2. Check that the ICC system is normal.

>> INSPECTION END

A
B
C
D
E
F
G
H
I
J
K
L
M
N
P

CCS

ICC STEERING SWITCH (OTHER THAN MAIN SWITCH) DOES NOT FUNCTION

< SYMPTOM DIAGNOSIS >

[ICC]

ICC STEERING SWITCH (OTHER THAN MAIN SWITCH) DOES NOT FUNCTION

Description

INFOID:00000000562648

MAIN switch can be turned ON/OFF, but the operation of RESUME/ACCELERATE switch, CANCEL switch, and DISTANCE switch cannot be performed during ICC system operation.

NOTE:

Resume is not accepted when the following condition is met.

- When the MAIN switch is turned OFF once.

Diagnosis Procedure

INFOID:00000000562649

1. CHECK EACH SWITCH

1. Start the engine.
2. Check that each switch operates normally on "DATA MONITOR" of "ICC" with CONSULT-III.
 - "RESUME/ACC SW"
 - "CANCEL SW"
 - "DISTANCE SW"

Is the inspection result normal?

- YES >> GO TO 5.
NO >> GO TO 2.

2. PERFORM ALL OF THE SELF-DIAGNOSIS ITEMS

1. Perform "All DTC Reading".
2. Check if the "U1000" is detected in "Self Diagnostic Result" of "ICC".

Is "U1000" detected?

- YES >> GO TO 3.
NO >> GO TO 4.

3. CAN COMMUNICATIONS INSPECTION

Check the CAN communication and repair or replace malfunctioning parts. Refer to [CCS-99, "DTC Logic"](#).

>> INSPECTION END

4. CHECK ICC STEERING SWITCH

Check the ICC steering switch. Refer to [CCS-61, "Component Inspection"](#).

>> GO TO 6.

5. REPLACE ICC SENSOR INTEGRATED UNIT

1. Replace the ICC sensor integrated unit. Refer to [CCS-135, "Exploded View"](#).
2. Adjust the laser beam aiming. Refer to [CCS-116, "DTC Index"](#).

>> GO TO 6.

6. CHECK ICC SYSTEM

1. Erase the self-diagnosis results, and then perform "All DTC Reading" again after performing the action test. (Refer to [CCS-11, "ACTION TEST : Description"](#) for action test.)
2. Check that the ICC system is normal.

>> INSPECTION END

ICC SYSTEM DOES NOT CANCEL WHEN A/T SELECTOR LEVER SETS ON "N"

Description

INFOID:000000005622650

The ICC system is not canceled even when the A/T selector lever is shifted to the N position while the ICC system is active.

Diagnosis Procedure

INFOID:000000005622651

1. CHECK D RANGE SWITCH

Check if "D RANGE SW" operates normally in "DATA MONITOR" of "ICC" with CONSULT-III.

Is the inspection result normal?

- YES >> GO TO 6.
- NO >> GO TO 2.

2. PERFORM ALL SELF-DIAGNOSIS ITEMS

1. Perform "All DTC Reading".
2. Check if the "U1000" is detected in "self-diagnosis results" of "ICC".

Is "U1000" detected?

- YES >> GO TO 3.
- NO >> GO TO 4.

3. CAN COMMUNICATIONS INSPECTION

Check the CAN communication and repair or replace malfunctioning parts. Refer to [CCS-99, "DTC Logic"](#).

>> INSPECTION END

4. CHECK POSITION SWITCH

Check if "SLCT LVR POSI" operates normally in "DATA MONITOR" of "TRANSMISSION".

Is the inspection result normal?

- YES >> GO TO 6.
- NO >> GO TO 5.

5. PERFORM TCM SELF-DIAGNOSIS

1. Perform the "Self Diagnostic Result" of "TRANSMISSION".
2. Repair or replace malfunctioning parts. Refer to [TM-253, "DTC Index"](#).

>> GO TO 7.

6. REPLACE ICC SENSOR INTEGRATED UNIT

1. Replace the ICC sensor integrated unit. Refer to [CCS-135, "Exploded View"](#).
2. Perform the laser beam aiming. Refer to [CCS-6, "LASER BEAM AIMING ADJUSTMENT : Description"](#).

>> GO TO 7.

7. CHECK ICC SYSTEM

1. Erase the self-diagnosis results, and then perform "All DTC Reading" again after performing the action test. (Refer to [CCS-11, "ACTION TEST : Description"](#) for action test.)
2. Check that the ICC system is normal.

>> INSPECTION END

CHIME DOES NOT SOUND

< SYMPTOM DIAGNOSIS >

[ICC]

CHIME DOES NOT SOUND

Description

INFOID:000000005622652

Symptom check: In the following conditions, the warning chime may not sound even if the vehicle distance is short.

- When the vehicles are traveling at the same speed and the distance between vehicles is not changing.
- When the vehicle ahead is traveling faster and the distance between vehicles is increasing.
- The warning chime will not sound when the accelerator pedal is depressed, overriding the system.
- The warning chime will not sound when own vehicle approaches vehicles that are parked or moving slowly.
- The warning chime does not sound when the system does not detect any vehicle ahead. (Diagnose the conditions under which the system is detecting the vehicle ahead and when the system is malfunctioning. If there is any malfunction in detecting the vehicle ahead, check the system following the [CCS-127, "Description"](#).)

Diagnosis Procedure

INFOID:000000005622653

1.PERFORM ACTIVE TEST

Check if the warning chime sounds on the active test item "ICC BUZZER" of "ICC" with CONSULT-III.

Does the warning chime sound?

- YES >> GO TO 2.
NO >> GO TO 3.

2.CHECK THE MALFUNCTION SYMPTOM DURING WARNING CHIME OPERATION

1. Understand the vehicle ahead detecting condition when the malfunction occurred. If the warning chime should have sounded, replace the ICC sensor integrated unit. Refer to [CCS-135, "Exploded View"](#).
2. Adjust the laser beam aiming. Refer to [CCS-6, "LASER BEAM AIMING ADJUSTMENT : Description"](#).

>> GO TO 8.

3.PERFORM THE SELF-DIAGNOSIS

1. Perform "All DTC Reading" with CONSULT-III.
2. Check if the "U1000" is detected in self-diagnosis results of "ICC".

Is "U1000" detected?

- YES >> GO TO 4.
NO >> GO TO 5.

4.CAN COMMUNICATIONS SYSTEM INSPECTION

Check the CAN communication system and repair or replace malfunctioning parts. Refer to [CCS-99, "DTC Logic"](#).

>> INSPECTION END

5.PERFORM SELF-DIAGNOSIS OF UNIFIED METER AND A/C AMP.

1. Perform "Self Diagnostic Result" of "METER/M&A".
2. Check if DTC is detected. Refer to [MWI-102, "DTC Index"](#).

Is any DTC detected?

- YES >> Repair or replace malfunctioning parts.
NO >> GO TO 6.

6.CHECK COMBINATION METER CHIME OPERATION

Check meter buzzer. Refer to [WCS-22, "Component Function Check"](#).

Is the inspection result normal?

- YES >> GO TO 7.
NO >> Repair or replace malfunctioning parts.

7.REPLACE ICC SENSOR INTEGRATED UNIT

1. Replace the ICC sensor integrated unit. Refer to [CCS-135, "Exploded View"](#).

CHIME DOES NOT SOUND

< SYMPTOM DIAGNOSIS >

[ICC]

2. Adjust the laser beam aiming. Refer to [CCS-6, "LASER BEAM AIMING ADJUSTMENT : Description"](#).

>> GO TO 8.

8.CHECK ICC SYSTEM

1. Erase the self-diagnosis results, and then perform "All DTC Reading" again after performing the action test. (Refer to [CCS-11, "ACTION TEST : Description"](#) for action test.)
2. Check that the ICC system is normal.

>> INSPECTION END

A
B
C
D
E
F
G
H
I
J
K
L
M
N
P

CCS

DRIVING FORCE IS HUNTING

Description

INFOID:000000005622654

The vehicle causes hunting when the ICC system is active.

Diagnosis Procedure

INFOID:000000005622655

1.PERFORM SELF-DIAGNOSIS OF ECM

1. Perform "All DTC Reading" with CONSULT-III.
2. Check if the DTC is detected in self-diagnosis results of "ENGINE". Refer to [EC-548, "DTC Index"](#).

Is any DTC detected?

- YES >> GO TO 3.
NO >> GO TO 2.

2.CHECK ICC SENSOR INTEGRATED UNIT BODY WINDOW

1. Check the vehicle driving conditions. Refer to [CCS-128, "Description"](#).
2. Check the ICC sensor integrated unit body window for contamination, foreign materials, or cracks. Refer to [CCS-128, "Diagnosis Procedure"](#).

>> INSPECTION END

3.REPAIR OR REPLACE MALFUNCTIONING PARTS

Repair or replace malfunctioning parts identified by the self-diagnosis result.

>> GO TO 4.

4.CHECK ICC SYSTEM

1. Erase the self-diagnosis results, and then perform "All DTC Reading" again after performing the action test. (Refer to [CCS-11, "ACTION TEST : Description"](#) for action test.)
2. Check that the ICC system is normal.

>> INSPECTION END

FREQUENTLY CANNOT DETECT THE VEHICLE AHEAD / DETECTION ZONE IS SHORT

< SYMPTOM DIAGNOSIS >

[ICC]

FREQUENTLY CANNOT DETECT THE VEHICLE AHEAD / DETECTION ZONE IS SHORT

Description

INFOID:000000005622656

The detection function may become unstable in the following cases.

- When the reflector of the vehicle ahead is deficient/ not clean enough to reflect the radar.
- When driving a road with extremely sharp corners.
- When the sensor cannot detect the reflector of the vehicle ahead as the vehicle ahead is passing a hill or passing the peak.

Diagnosis Procedure

INFOID:000000005622657

1.VISUAL CHECK (1)

Check ICC sensor integrated unit body window for contamination and/or foreign materials.

Do foreign materials adhere?

- YES >> GO TO 2.
- NO >> GO TO 3.

2.REMOVE DIRT AND FOREIGN MATERIALS

Remove the contamination and foreign materials from the ICC sensor integrated unit body window.

>> GO TO 6.

3.VISUAL CHECK (2)

Check ICC sensor integrated unit body window for cracks and scratches.

Are there any cracks or scratches?

- YES >> GO TO 5.
- NO >> GO TO 4.

4.ADJUST LASER BEAM AIMING

1. Adjust the laser beam aiming. Refer to [CCS-6, "LASER BEAM AIMING ADJUSTMENT : Description"](#).
2. Perform ICC system action test. Refer to [CCS-11, "ACTION TEST : Description"](#).
3. Check that the vehicle ahead detection performance improves.

Does it improve?

- YES >> INSPECTION END
- NO >> GO TO 5.

5.REPLACE ICC SENSOR INTEGRATED UNIT

1. Replace the ICC sensor integrated unit. Refer to [CCS-135, "Exploded View"](#).
2. Adjust the laser beam aiming. Refer to [CCS-6, "LASER BEAM AIMING ADJUSTMENT : Description"](#).

>> GO TO 6.

6.CHECK ICC SYSTEM

1. Erase the self-diagnosis results, and then perform "All DTC Reading" again after performing the action test. (Refer to [CCS-11, "ACTION TEST : Description"](#) for action test.)
2. Check that the ICC system is normal.

>> INSPECTION END

A
B
C
D
E
F
G
H
I
J
K
L
M
N
P

THE SYSTEM DOES NOT DETECT THE VEHICLE AHEAD AT ALL

< SYMPTOM DIAGNOSIS >

[ICC]

THE SYSTEM DOES NOT DETECT THE VEHICLE AHEAD AT ALL

Description

INFOID:000000005622658

When ICC system is active, the ICC system does not perform any control even through there is a vehicle ahead.

Diagnosis Procedure

INFOID:000000005622659

1. CHECK ICC SYSTEM DISPLAY ON MULTI INFORMATION DISPLAY

1. Start the self-diagnosis mode of combination meter. Refer to [MWI-33. "Diagnosis Description"](#).
2. Check that the multi information display turns on normally.

Is the inspection result normal?

- YES >> GO TO 2.
- NO >> Replace the combination meter.

2. VISUAL CHECK (1)

Check ICC sensor integrated unit body window for contamination and/or foreign materials.

Do foreign materials adhere?

- YES >> GO TO 3.
- NO >> GO TO 4.

3. WIPE OUT DIRT AND FOREIGN MATERIALS

Wipe out the contamination and/or foreign materials from the ICC sensor integrated unit body window.

>> GO TO 7.

4. VISUAL CHECK (2)

Check ICC sensor integrated unit body window for cracks and/or scratches.

Are there cracks?

- YES >> GO TO 6.
- NO >> GO TO 5.

5. LASER BEAM AIMING ADJUSTMENT

1. Adjust the laser beam aiming. Refer to [CCS-6. "LASER BEAM AIMING ADJUSTMENT : Description"](#).
2. Perform ICC system action test. Refer to [CCS-11. "ACTION TEST : Description"](#).
3. Check that the vehicle ahead detection performance improves.

Does it improve?

- YES >> INSPECTION END
- NO >> GO TO 6.

6. REPLACE ICC SENSOR INTEGRATED UNIT

1. Replace the ICC sensor integrated unit. Refer to [CCS-135. "Exploded View"](#).
2. Adjust the laser beam aiming. Refer to [CCS-6. "LASER BEAM AIMING ADJUSTMENT : Description"](#).

>> GO TO 7.

7. CHECK ICC SYSTEM

1. Erase the self-diagnosis results, and then perform "All DTC Reading" again after performing the action test. (Refer to [CCS-11. "ACTION TEST : Description"](#) for action test.)
2. Check that the ICC system is normal.

>> INSPECTION END

NORMAL OPERATING CONDITION

< SYMPTOM DIAGNOSIS >

[ICC]

NORMAL OPERATING CONDITION

Description

INFOID:000000005622660

PRECAUTIONS FOR VEHICLE-TO-VEHICLE DISTANCE CONTROL MODE

CAUTION:

- ICC system is only an aid to assist the driver and is not a collision warning or avoidance device. It is the driver's responsibility to stay alert, drive safely and be in control of the vehicle at all times.
- The system is primarily intended for use on straight, dry, open roads with light traffic. It is not advisable to use the system in city traffic or congested areas.
- This system will not adapt automatically to road conditions. This system should be used in evenly flowing traffic. Do not use the system on roads with sharp curves, or on icy roads, in heavy rain or in fog.
- The distance sensor will not detect under most conditions.
 - Stationary and slow moving vehicles.
 - Pedestrians or objects in the roadway.
 - Oncoming vehicles in the same lane.
 - Motorcycles traveling offset in the travel lane.
- As there is a performance limit to the distance control function, never rely solely on the ICC system. This system does not correct careless, inattentive or absent-minded driving, or overcome poor visibility in rain, fog, or other bad weather. Decelerate the vehicle speed by depressing the brake pedal, depending on the distance to the vehicle ahead and the surrounding circumstances in order to maintain a safe distance between vehicles.
- Although the brake operation is controlled by the system, the system does not automatically stop the vehicle. If the vehicle speed falls below approximately 32 km/h (20 MPH), the Intelligent Cruise Control system is automatically canceled and a warning chime sounds. (The brake control is also canceled.)
- The system may not detect the vehicle in front of the driver in certain road or weather conditions. To avoid accidents, never use the ICC system under the following conditions:
 - On roads where the traffic is heavy or there are sharp curves.
 - On slippery road surfaces such as on ice or snow, etc.
 - During bad weather (rain, fog, snow, etc.)When the front wiper is operated at the low speed (LO) or high speed (HI) position, the ICC system is automatically canceled.
 - When strong light (for example, at sunrise or sunset) is directly shining on the front of the vehicle.
 - When rain, snow or dirt adhere to the system sensor.
 - On steep downhill roads (the vehicle may go beyond the set vehicle speed and frequent braking may result in overheating the brakes).
 - On repeated uphill and downhill roads.
 - When traffic conditions make it difficult to keep a proper distance between vehicles because of frequent acceleration or deceleration.
- Do not use the ICC system if own vehicle is towing a trailer. The system may not detect a vehicle ahead.
- In some road or traffic conditions, a vehicle or object can unexpectedly come into the sensor detection zone and cause automatic braking. The driver may need to control the distance from other vehicles using the accelerator pedal. Always stay alert and avoid using the ICC system when it is not recommended in this section.
- The vehicle-to-vehicle distance control mode uses a sensor located on the front of the vehicle to detect vehicles traveling ahead. The sensor generally detects the signals returned from the reflectors on a vehicle ahead. Therefore, if the sensor cannot detect the reflector on the vehicle ahead, the ICC system may not maintain the selected distance.
 - The following are some conditions in which the sensor cannot detect the signals:
 - When the reflector of the vehicle ahead is positioned high on the vehicle (trailer, etc.).
 - When the reflector on the vehicle ahead is missing, damaged or covered.
 - When the reflector of the vehicle ahead is covered with dirt, snow and road spray.
 - When the snow or road spray from traveling vehicles reduces the sensor's visibility.
 - When dense exhaust or other smoke (black smoke) from vehicles reduces the sensor's visibility.
 - When excessively heavy baggage is loaded in the rear seat or the luggage room of own vehicle.
- The ICC system is designed to automatically check the sensor's operation within the limitation of the system. When the sensor is covered with dirt or is obstructed, the system will automatically be canceled. If the sensor is covered with ice, a transparent or translucent vinyl bag, etc., the ICC system

A
B
C
D
E
F
G
H
I
J
K
L
M
N

CCS

P

NORMAL OPERATING CONDITION

< SYMPTOM DIAGNOSIS >

[ICC]

may not detect them. In these instances, the vehicle-to-vehicle distance control mode may not cancel and may not be able to maintain the selected following distance from the vehicle ahead. Be sure to check and clean the sensor regularly.

- The ICC system does not control vehicle speed or warn the driver when own vehicle approaches stationary and slow moving vehicles. The driver must pay attention to vehicle operation to maintain proper distance from vehicles ahead when approaching toll gates or traffic congestion.
- The detection zone of the ICC sensor is limited. A vehicle ahead must be in the detection zone for the vehicle-to-vehicle distance detection mode to maintain the selected distance from the vehicle ahead. A vehicle ahead may move outside of the detection zone due to its position within the same lane of travel. Motorcycles may not be detected in the same lane ahead if they are traveling offset from the center line of the lane. A vehicle that is entering the lane ahead may not be detected until the vehicle has completely moved into the lane. If this occurs, the ICC system may warn the driver by blinking the system indicator and sounding the chime. The driver may have to manually control the proper distance away from vehicle traveling ahead.

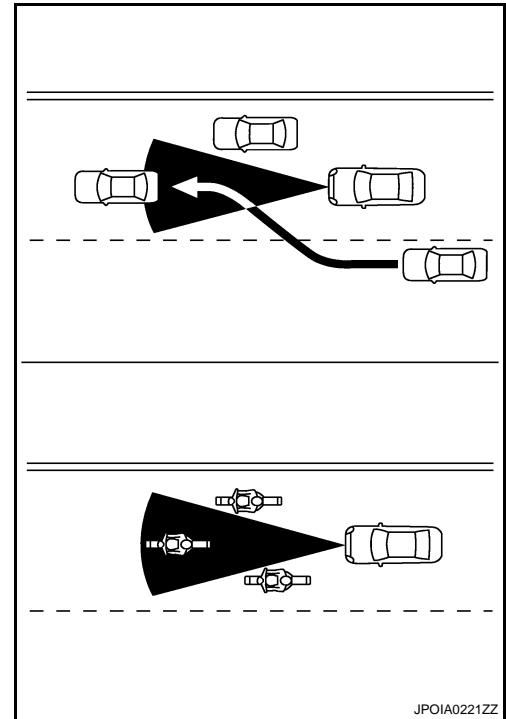

- When driving on some roads, such as winding, hilly, curved, narrow roads, or roads which are under construction, the ICC sensor may detect vehicles in a different lane, or may temporarily not detect a vehicle traveling ahead. This may cause the ICC system to decelerate or accelerate the vehicle. The detection of vehicles may also be affected by vehicle operation (steering maneuver or traveling position in the lane, etc.) or vehicle condition. If this occurs, the ICC system may warn the driver by blinking the system indicator and sounding the chime unexpectedly. The driver will have to manually control the proper distance away from the vehicle traveling ahead.

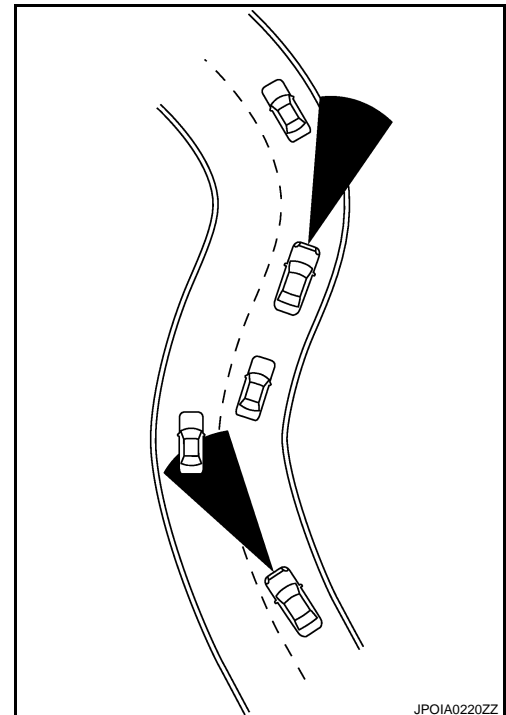

NORMAL OPERATING CONDITION

< SYMPTOM DIAGNOSIS >

[ICC]

- When driving on the freeway at a set speed and approaching a slower traveling vehicle ahead, the ICC will adjust the speed to maintain the distance, selected by the driver, from the vehicle ahead. If the vehicle ahead changes lanes or exits the freeway, the ICC system will accelerate and maintain the speed up to the set speed. Pay attention to the driving operation to maintain control of the vehicle as it accelerates to the set speed. The vehicle may not maintain the set speed on winding or hilly roads. If this occurs, the driver will have to manually control the vehicle speed.

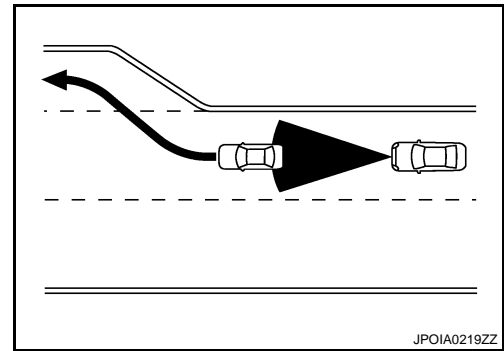

- The sensor sensitivity can be affected by vehicle operation (steering maneuver or driving position in the lane) or traffic or vehicle condition (for example, if a vehicle is being driven with some damage).
- Normally when controlling the distance to a vehicle ahead, this system automatically accelerates or decelerates own vehicle according to the speed of the vehicle ahead. Depress the accelerator to properly accelerate own vehicle when acceleration is required for a lane change. Depress the brake pedal when deceleration is required to maintain a safe distance to the vehicle ahead due to its sudden braking or if a vehicle cuts in. Always stay alert when using the ICC system.

PRECAUTIONS FOR CONVENTIONAL (FIXED SPEED) CRUISE CONTROL MODE

CAUTION:

- In the conventional (fixed speed) cruise control mode, a warning chime does not sound to warn the driver if own vehicle is too close to the vehicle ahead, as neither the presence of the vehicle ahead nor the vehicle-to-vehicle distance is detected.
- Pay special attention to the distance between own vehicle and the vehicle ahead or a collision could occur.
- Always confirm the setting in the ICC system display.
- Do not use the conventional (fixed speed) cruise control mode when driving under the following conditions:
 - when it is not possible to keep the vehicle at a set speed.
 - in heavy traffic or in traffic that varies in speed.
 - on winding or hilly roads.
 - on slippery roads (rain, snow, ice, etc.).
 - in very windy areas.
- Doing so could cause a loss of vehicle control and result in an accident.
- To avoid accidentally engaging cruise control, make sure to the MAIN switch OFF when not using ICC system.

A
B
C
D
E
F
G
H
I
J
K
L
M
N
P

CCS

PRECAUTION

PRECAUTIONS

Precaution for Supplemental Restraint System (SRS) "AIR BAG" and "SEAT BELT PRE-TENSIONER"

INFOID:000000005622661

The Supplemental Restraint System such as "AIR BAG" and "SEAT BELT PRE-TENSIONER", used along with a front seat belt, helps to reduce the risk or severity of injury to the driver and front passenger for certain types of collision. This system includes seat belt switch inputs and dual stage front air bag modules. The SRS system uses the seat belt switches to determine the front air bag deployment, and may only deploy one front air bag, depending on the severity of a collision and whether the front occupants are belted or unbelted. Information necessary to service the system safely is included in the "SRS AIR BAG" and "SEAT BELT" of this Service Manual.

WARNING:

- To avoid rendering the SRS inoperative, which could increase the risk of personal injury or death in the event of a collision which would result in air bag inflation, all maintenance must be performed by an authorized NISSAN/INFINITI dealer.
- Improper maintenance, including incorrect removal and installation of the SRS, can lead to personal injury caused by unintentional activation of the system. For removal of Spiral Cable and Air Bag Module, see the "SRS AIR BAG".
- Do not use electrical test equipment on any circuit related to the SRS unless instructed to in this Service Manual. SRS wiring harnesses can be identified by yellow and/or orange harnesses or harness connectors.

PRECAUTIONS WHEN USING POWER TOOLS (AIR OR ELECTRIC) AND HAMMERS

WARNING:

- When working near the Air Bag Diagnosis Sensor Unit or other Air Bag System sensors with the ignition ON or engine running, DO NOT use air or electric power tools or strike near the sensor(s) with a hammer. Heavy vibration could activate the sensor(s) and deploy the air bag(s), possibly causing serious injury.
- When using air or electric power tools or hammers, always switch the ignition OFF, disconnect the battery, and wait at least 3 minutes before performing any service.

Precaution for Battery Service

INFOID:000000005622662

Before disconnecting the battery, lower both the driver and passenger windows. This will prevent any interference between the window edge and the vehicle when the door is opened/closed. During normal operation, the window slightly raises and lowers automatically to prevent any window to vehicle interference. The automatic window function will not work with the battery disconnected.

Service Procedure Precautions for Models with a Pop-up Roll Bar

INFOID:000000005622663

WARNING:

- Risk of passenger injury or death may increase if the pop-up roll bar does not deploy during a roll over collision. In order to reduce the chance of an incident where the pop-up roll bar is inoperative, all maintenance must be performed by a NISSAN or INFINITI dealer.
- Before removing and installing the pop-up roll bar component parts and harness, always turn the ignition switch OFF, disconnect the battery negative terminal, and wait for 3 minutes or more. (The purpose of this operation is to discharge electricity that is accumulated in the auxiliary power supply circuit in the air bag diagnosis sensor unit.)
- When repairing, removing, and installing a pop-up roll bar, always refer to SRS AIR BAG and SRS AIR BAG CONTROL warnings in the Service Manual.

ICC System Service

INFOID:000000005622664

CAUTION:

- Never look straight into the laser beam discharger when adjusting laser beam aiming.
- Turn the MAIN switch OFF in conditions similar to driving, such as free rollers or a chassis dynamometer.
- Never use the ICC sensor integrated unit removed from vehicle. Never disassemble or remodel.

PRECAUTIONS

< PRECAUTION >

[ICC]

- Erase DTC when replacing parts of ICC system, then check the operation of ICC system after adjusting laser beam aiming if necessary.

A

B

C

D

E

F

G

H

I

J

K

L

M

N

CCS

P

PREPARATION

PREPARATION

Special Service Tools

INFOID:000000005622665

The actual shapes of Kent-Moore tools may differ from those of special service tools illustrated here.

Tool number (Kent-Moore No.) Tool name	Description
<p>KV99110100 (J-45718) ICC target board</p>  <p>PKIA0358J</p>	<p>Uses for laser beam aiming adjustment</p>

ICC SENSOR INTEGRATED UNIT

< REMOVAL AND INSTALLATION >

[ICC]

REMOVAL AND INSTALLATION

ICC SENSOR INTEGRATED UNIT

Exploded View

INFOID:000000005622666

CAUTION:

Always perform the laser beam aiming adjustment and check the operation after the replacement, removal and installation of ICC sensor integrated unit.

NORMAL FRONT BUMPER FASCIA TYPE

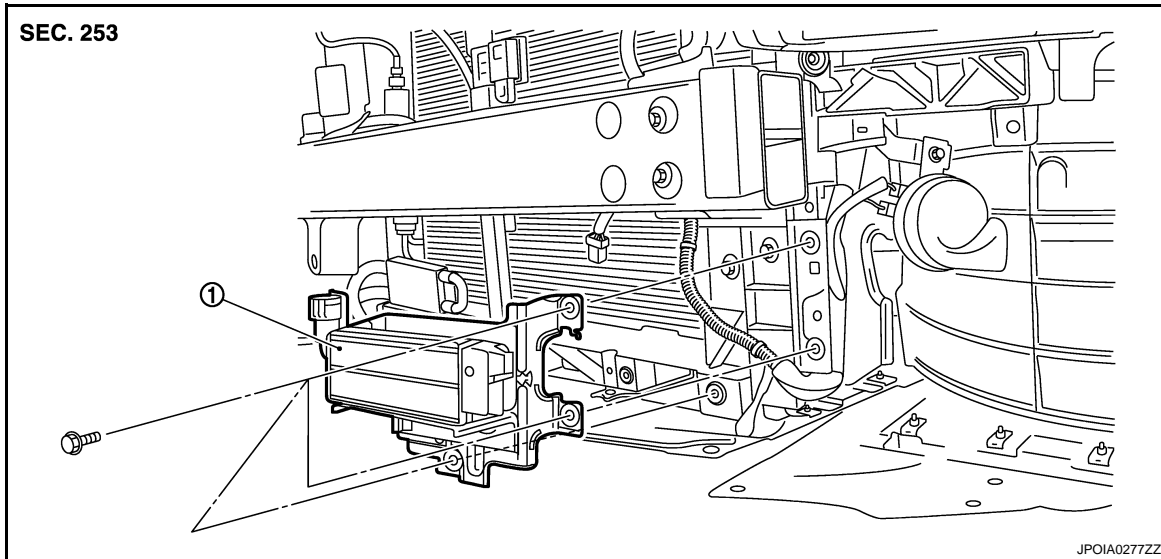

1. ICC sensor integrated unit

SPORT FRONT BUMPER FASCIA TYPE

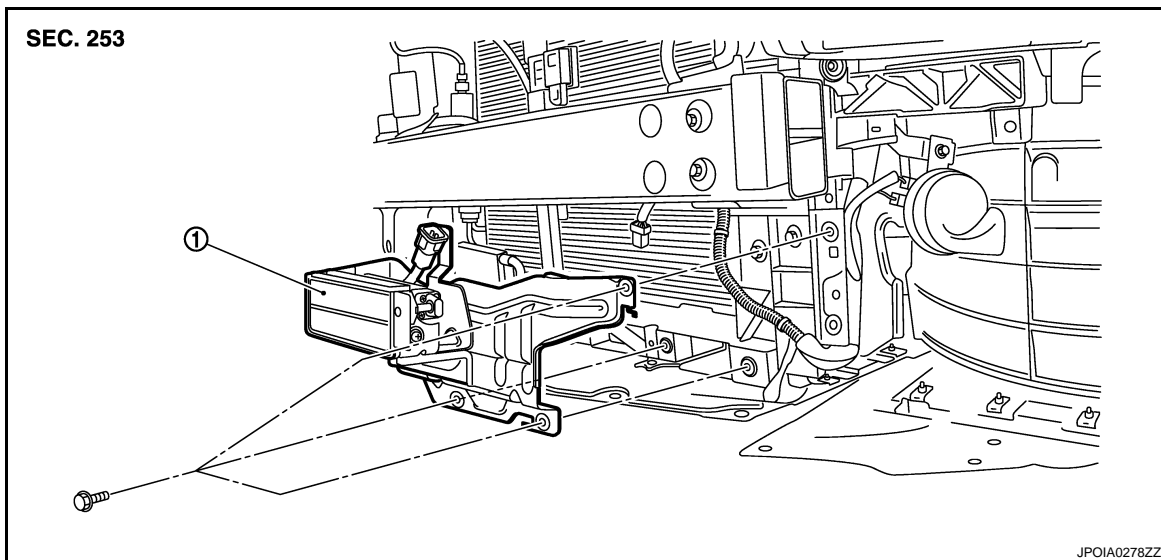

1. ICC sensor integrated unit

Removal and Installation

INFOID:000000005622667

REMOVAL

1. Remove front bumper fascia. Refer to [EXT-12, "Exploded View"](#).

A
B
C
D
E
F
G
H
I
J
K
L
M
N
P

CCS

ICC SENSOR INTEGRATED UNIT

[ICC]

< REMOVAL AND INSTALLATION >

2. Disconnect ICC sensor integrated unit connector.
3. Remove mounting bolts from ICC sensor integrated unit.
4. Remove ICC sensor integrated unit.

INSTALLATION

Install in the reverse order of removal.

CAUTION:

Always perform the laser beam aiming adjustment and check the operation after the replacement, removal, and installation of ICC sensor integrated unit. Refer to [CCS-6, "ADDITIONAL SERVICE WHEN REPLACING CONTROL UNIT \(ICC SENSOR INTEGRATED UNIT\) : Description"](#).

ICC STEERING SWITCH

< REMOVAL AND INSTALLATION >

[ICC]

ICC STEERING SWITCH

Exploded View

INFOID:000000005622668

Refer to [ST-14. "Exploded View"](#).

A
B
C
D
E
F
G
H
I
J
K
L
M
N
P

CCS